



徐工徐工 助您成功
XCMG FOR YOUR SUCCESS



地址：江苏省徐州市开发区鲲鹏北路99号
Address: No. 99, Kunpeng North Road, Development Zone, Xuzhou, Jiangsu, China
邮编：221004
Postal code: 221004
网址：www.ccxcmg.com
Website: www.ccxcmg.com
电话：0516-87560299
Phone No.: 0516-87560299



徐工叉车官网
XCMG forklift official website



徐工叉车微商城
"King of Forklift/Loader" micro mall



徐工叉车微信公众号
XCMG forklift WeChat official account

2020年第一版

全国统一客服热线：**400-110-9999**
Nationwide unified customer service hotline.

仓储叉车

Warehouse Forklift

徐工电动仓储叉车系列
XCMG Electric Warehouse Forklift Series

大国重器 中国脊梁:

China's Significant Product

20世纪40年代,沐浴着抗日战争的烽火,源起三大厂的徐工开启了与共和国同呼吸、共命运的奋斗历程。1989年,徐工集团正式成立。77载潜心专注,31年创新引领。徐工集团始终保持中国工程机械行业排头兵地位,是中国工程机械行业规模宏大、产品品种与系列齐全、独具竞争力和影响力的大型企业集团。

世界工程机械行业第4位,中国机械工业百强第4位,世界品牌500强第427位,沉着、大气的徐工集团坚守着大国重器的责任与使命,在产业报国的道路上稳健前行。

为祖国效力,为世界担当!未来,徐工集团将秉承“担大任、行大道、成大器”的核心价值观和“严格、踏实、上进、创新”的企业精神,向着梦想的珠峰不断攀登,成为全球信赖、具有独特价值创造力的世界级企业!

徐工徐工,助您成功!

In the 1940s, under the background of the War of Resistance against Japan, XCMG, originated from three large factories, started the struggling course in company with the People's Republic of China.

In 1989, XCMG was officially founded. Through 77 years of concentrated efforts and 31 years of pioneering innovations, XCMG always maintains the leading place in the China's construction machinery industry and is a large enterprise group with magnificent scale, complete product variety and series, and unique competitiveness and influence in China's construction machinery industry.

Ranked in the 4th place in world's construction machinery industry, the 4th place in China's top 100 mechanical industry enterprises, and the 427th place in global 500 top brands, the imperturbable and elegant XCMG adheres to the responsibilities of missions of China's Significant Product and is marching forward steadily in the course of serving the country with industry.

Ranked in the 4th place in world's construction machinery industry, the 4th place in China's top 100 mechanical industry enterprises, and the 427th place in global 500 top brands, the imperturbable and elegant XCMG adheres to the responsibilities of missions of China's Significant Product and is marching forward steadily in the course of serving the country with industry.

Making contributions to the country and assuming the responsibilities for the world, in the future, XCMG will undertake the core value of "Assuming great responsibility, treading great course, and achieving great success" and the corporate spirit of "Stringent, steadfast, progressive, and innovative" and march towards the dreaming summit to become a globally trustworthy world-class enterprise with unique value creativity.

XCMG helps your great success!



卓越服务 精品形象:

Service excellence and quality product image

只有客户的成功,才能有企业自身的成功。徐工铲运始终坚持“客户价值最大化”的理念,在创新技术、提升质量的同时,更加注重服务网站建设,目前已在全国建成800多个销售服务网点。

Only the customer's success can lead to the enterprise's success. XCMG Earthmoving Machinery always insists on the concept of "Customer value maximization" and pays more attention to the building of service networks while innovating the technologies and improving the quality. At present, it has built more than 800 sales and service stations around the

服务理念: Service concept:

致力卓越服务,树立精品形象。Devoting to service excellence and establishing quality product image.

服务承诺: Service commitments:

车到人到 交接完好 主动服务 内容全面

On-time delivery service Intact handover Proactive service Comprehensive contents

热线追踪 培训指导 终身维修 快速高效

Hot-line tracking Training and instructions Lifelong repair Rapidness and high efficiency



遍布全国的服务中心
Nationwide service center



服务快速、及时、有效
Fast, timely, and effective services



功能齐全的4S店
Full-featured 4S shops



目录 CONTENTS

01 电动托盘搬运车 ▼ Electric Pallet Truck



步行式托盘搬运车 —— 2-4 页
Walkie pallet truck Page 1-8



站架式托盘搬运车 —— 5-8 页
Stand-on pallet truck Page 9-10

02 电动托盘堆垛车 ▼ Electric Pallet Stacker



步行式托盘堆垛车 —— 9-14 页
Walkie pallet stacker Page 11-16



站架式托盘堆垛车 —— 15-18 页
Stand-on pallet stacker Page 17-20

03 前移叉车 ▼ Reach Forklift



站驾式前移叉车 —— 19-20 页
Stand-on reach forklift Page 21-22



座驾式前移叉车 —— 21-22 页
Sit-on reach forklift Page 23-24

04 牵引车 ▼ Tow Tractor



站驾式牵引车 —— 23-26 页
Stand-on tow tractor Page 25-28



座驾式牵引车 —— 27-28 页
Sit-on tow tractor Page 29-30

电动托盘搬运车 ▼ Electric Pallet Truck

步行式托盘搬运车——XCC-LW15 (微螳螂)

Walkie Pallet Truck - XCC-LW15 (Mini Mantis)



产品特点: Best-selling

- 坚固的全防护驱动罩设计, 可对操作者足部充分防护;
- The firm full-protected drive hood design can sufficiently protect the operator's feet.
- 模块化设计, 全电动和半电动配置零部件通用化程度高;
- The modular design realizes high parts interchangeability degree for full-electric and semi-electric models.
- 装配式前盖板, 方便维修和更换电驱元器件;
- The assembled front cover plate eases the repairs and replacements of electric parts.
- 可选装大尺寸浮动型转向轮, 提高整车稳定性;
- The optional large-size floating steering wheels improve the machine stability.
- 承载轮可选装单轮或双轮;
- The optional single or double load-carrying wheels are offered.
- 有多种规格货叉可供选择。
- The forks of diversified specifications are offered at choice.



仪表集成了电量显示功能, 故障代码显示, 一键开机, 三档调速等功能。标配急停开关, 三档调速更合理, 在紧急情况下能使快速的实施制动。

The instrument is integrated with power-level display, trouble code display, one-touch power-on, and three-speed regulation functions. The standard emergency stop switch is provided at more reasonable position to apply the braking quickly and conveniently in event of any emergency.

采用人体工学设计, 弹性环保材质, 摒弃硬化塑料, 操作舒适, 绝缘减震, 所有的开关按钮都集成在人性化触及其位置, 方便操作, 大幅优化了操作舒适性。

The ergonomic design is applied and the environmental-friendly elastic materials are used in place of the hard plastics to ensure comfortable operations and good insulation and damping performance. All switches and buttons are integrated at humanized and easily accessible positions to ease the operations and remarkably optimize the operating comfort.

满载 5% 空载 15%
5% under full-load condition and 15% under no-load condition
额定载重 1500kg 的情况下可以爬坡 5%, 空载爬坡 16%, 灵活操作更自由。
The gradeability is 5% under and 1,500kg rated load condition and is 16% under no-load condition to ensure more free operating flexibility.

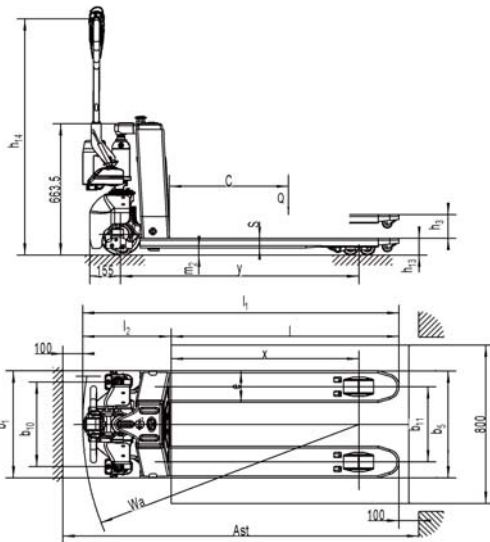

工业车辆参数表 Industrial vehicle specification				
特性 Characteristics	1.1	型号 Model	XCC-LW15 微螳螂 XCC-LW15 Mini Mantis	
	1.2	动力 Power system	电动 Electric	
	1.3	操作类型 Operating type	步行式 Walkie type	
	1.4	额定载荷能力 Rated load capacity	Q(t)	1.5
	1.5	载荷中心距 Center distance of load	c(mm)	600
	1.6	前悬距 Front overhang	x(mm)	950
	1.7	轴距 Wheelbase	y(mm)	1200
重量 Weights	2.1	自重 Dead weight	kg	130
	2.2	满载时桥负荷, 驱动侧/承重侧 Full-load axle load, drive/load-carrying end	kg	570/1060
	2.3	空载时桥负荷, 驱动侧/承重侧 No-load axle load, drive/load-carrying end	kg	100/30
轮子、底盘 Wheels and chassis	3.1	轮子 Wheels		聚氨酯轮 Polyurethane wheels
	3.2	轮子尺寸, 驱动侧 Wheel size, drive end	Øxw(mm)	Ø210×70
	3.3	轮子尺寸, 承重侧 Wheel size, load-carrying end	Øxw(mm)	Ø80×93/ø80×70
	3.4	稳定轮 (尺寸) Stabilizing wheel (Size)	Øxw(mm)	-/ø80×30
	3.5	轮子数量 (X=驱动轮) Number of wheels (X=drive wheel), drive/load-carrying end		1×2
	3.6	轮距, 驱动侧 Wheel tread, drive end	b10(mm)	-/430
	3.7	轮距, 承重侧 Wheel tread, load-carrying end	b11(mm)	380/525
基本尺寸 Basic dimensions	4.1	提升高度 Lifting height	h3(mm)	115
	4.2	作业时手柄高度, 最小/最大 Handle height during operations, minimum/maximum	h14(mm)	680/1190
	4.3	货叉降低时高度 Height with forks lowered	h13(mm)	80
	4.4	总体长度 Overall length	l1(mm)	1595
	4.5	车体长度 Body length	l2(mm)	445
	4.6	总体宽度 Overall width	b1(mm)	540/685
	4.7	货叉尺寸 Fork size	s/c1(mm)	47/160/1150
	4.8	货叉外宽 Outer width of forks	b5(mm)	540/685
	4.9	最小离地间隙 Minimum ground clearance	m2(mm)	37
性能 Performances	4.10	通道宽度800×1200沿货叉放置 (200安全距离) Aisle width for pallets 800×1,200 lengthwise (200 safety gap)	Ast(mm)	1861
	4.11	转弯半径 Turning radius	Wa(mm)	1390
电机 Motor	5.1	行驶速度 满载/空载 Traveling speed, full-load/no-load	km/h	4.5/4.8
	5.2	提升速度 满载/空载 Lifting speed, Full-load/no-load	mm/s	15/20
	5.3	下降速度 满载/空载 Lowering speed, full-load/no-load	mm/s	60/40
	5.4	最大爬坡能力 满载/空载 Maximum gradeability, full-load/no-load	%	5/15
	5.5	行车制动 Service brake		电磁制动 Electromagnetic brake
其它 Others	6.1	驱动电机功率S2 60min Drive motor power S2 60min	kW	0.75
	6.2	提升电机功率S3 8% Lifting motor power S3 8%	kW	0.8
	6.3	蓄电池 根据DIN 43531/35/36A,B, C标准 Battery, as per DIN 43531/35/36 A, B, C		No
	6.4	蓄电池电压, 额定容量K5 Battery voltage, rated capacity K5	V/Ah	48V/12Ah
	6.5	蓄电池重量 (+/-5%) Battery weight (+/-5%)	kg	5
	6.6	根据VDI循环的能耗 Energy consumption as per VDI cycle	kWh/h	0.1
其它 Others	7.1	驱动控制方式 Drive control mode		直流无刷控制 DC brushless control
	7.2	驾驶员耳边噪声水平, 根据EN12053标准 Driver's parotic noise level, as per EN12053	dB(A)	<70

随技术进步, 产品结构、参数等将不断改进, 恕不另行通知, 样本信息与实物略有不符的, 以实物为准。
The continuous improvements of product structure and parameters along with the technologic progress will be made without further notice. In event of any discrepancy between brochure information and real product, the real product shall prevail.

电动托盘搬运车 ▼ Electric Pallet Truck

步行式托盘搬运车——XCC-LW15/20(小螳螂)

Walkie Pallet Truck - XCC-LW15/20 (Small Mantis)



产品特点: Best-selling

手柄采用弹性环保材质, 操作舒适, 绝缘减震, 优化操作人员的舒适性。所有开关按钮都在人性化触及位置, 方便操作。内置密码锁和LCD显示屏, 实现对车子的智能操控。

The handle is made of environmental-friendly elastic material to realize comfortable operations and good insulation and damping and optimize the operator's comfort. All switches and buttons are arranged at humanized and easily accessible positions to ease the operations. The built-in password lock and LCD screen realize the intelligent control of the machine.

整车可实现手柄直立位置行走功能, 确保车辆在货车、电梯或狭小空间内可以安全的行进转弯等操作。

The machine can realize the traveling function with vertical handle to ensure the safe traveling and steering operations within a truck, elevator, or narrow space.

车架采用金属覆盖件, 可对内部的零部件起到保护作用。货叉采用大脚封设计, 进出托盘更快捷。全系车型标配平衡轮, 使得车身更加稳定可靠。

The frame adopts metal coverings to protect the internal parts. The forks are designed with large foot seals for quick insertion into and withdrawal from the pallets. The whole series is equipped with standard balancing wheel to realize higher stability and reliability of the machine body.

采用独立充电接口, 无需取出电池即可随车充电。标配内置BMS电池管理系统的免维护智能锂电池和大功率充电器, 确保电池的出色性能得以智能控制和快速充电。

The independent charging coupler is applied to charge the battery without removing the battery from the machine. The maintenance-free intelligent lithium battery with standard built-in battery management system (BMS) and the high-power charger guarantee the outstanding performances of the battery and realize intelligent control and quick charging.

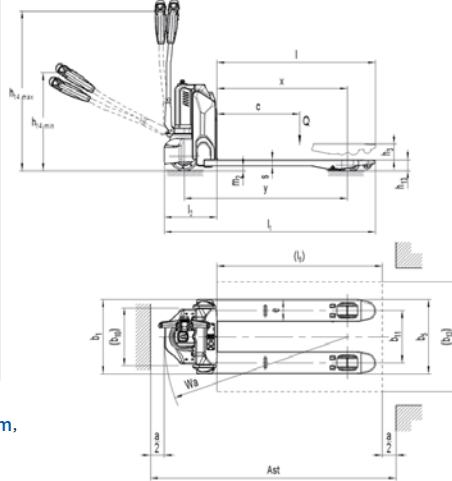

比一般的手动搬运车都小的车身设计(1.2T L2=387/1.5T L2=380/2.0T锂电 L2=386/2.0T铅酸 L2=478)优化了转弯半径, 2.0T款货叉起升时1280mm, 下降时1336mm, 1.5T款货叉起升时1274mm, 下降时1330mm车身紧凑, 可在狭小的空间中使用, 比如零售店、电梯、商业中心等。

The body design that is smaller than the conventional manual trucks (1.2T L2=387/1.5T L2=380/2.0T lithium battery L2=386/2.0T lead-acid battery L2=478) optimizes the turning radius. The body size is 1,280mm during lifting of forks and is 1,336mm during lowering of forks for 2.0T model. The body size is 1,274mm during lifting of forks and is 1,330mm during lowering of forks for 1.5T model. With compact body, this machine can be used in narrow spaces, such as retail stores, elevators, and business centers.

工业车辆参数表 Industrial vehicle specification							
特性 Characteristics	1.1	型号 Model	XCC -LW15		XCC -LW20		
	1.2	动力 Power system	电动 Electric				
	1.3	操作类型 Operating type	步行式 Walkie type				
	1.4	额定载重能力 Rated load capacity	Q(t)	1.5	2.0		
	1.5	载荷中心距 Center distance of load	c(mm)	600			
	1.6	前悬距 Front overhang	x(mm)	947	951		
	1.7	轴距 Wheelbase	y(mm)	1183	1189		
重量 Weights	2.1	自重 Dead weight	kg	123	126	149	153
	2.2	满载时桥负荷, 驱动侧/承重侧 Full load axle load, drive/load - carrying end	kg	623/1000	626/1000	621/1528	625/1528
	2.3	空载时桥负荷, 驱动侧/承重侧 No-load axle load, drive/load - carrying end	kg	96/27	99/27	115/34	11 9/34
轮子、底盘 and chassis	3.1	轮子 Wheels	聚氨酯胎 Polyurethane wheels				
	3.2	轮子尺寸, 驱动侧 Wheel size, drive end	Øxw(mm)	Ø210×70			
	3.3	轮子尺寸, 承重侧 Wheel size, load - carrying end	Øxw(mm)	Ø80×93/ø80×70			
	3.4	稳定轮(尺寸) Stabilizing wheel (Size)	Øxw(mm)	ø80×30			
	3.5	轮子数量(X=驱动侧/驱动侧 drive/load, Y=承重侧/承重侧 load - carrying end)		1x/2(1x/4)x+2/2(1x+2/4)			
	3.6	轮距, 驱动侧 Wheel tread, drive end	b10(mm)	- /430			
	3.7	轮距, 承重侧 Wheel tread, load - carrying end	b11(mm)	380	525	380	525
基本尺寸 Basic dimensions	4.1	提升高度 Lifting height	h3(mm)	115			
	4.2	作业时手柄高度, 最小/最大 Handle height during operations, minimum/maximum	h14(mm)	700/1160			
	4.3	货叉降低时高度 Height with forks lowered	h13(mm)	80			
	4.4	总体长度 Overall length	l1(mm)	1530	1536		
	4.5	车体长度 Body length	l2(mm)	380	386		
	4.6	总体宽度 Overall width	b1(mm)	540	685	540	685
	4.7	货叉尺寸 Fork size	s/e(mm)	47/160/1150			
	4.8	货叉外宽 Outer width of forks	b5(mm)	540	685	540	685
	4.9	最小离地间隙 Minimum ground clearance	m2(mm)	33			
	4.10	轴距宽度 800×1200 消防叉设置(200安全距离) Axle width for pallets 800 × 1,200 lengthwise (200 safety gap)	Ast(mm)	1783	1789		
4.11	转弯半径 Turning radius	Wa(mm)	1330	1336			
性能 Performances	5.1	行驶速度 满载/空载 Traveling speed, full - load/no - load	km/h	4.6/4.8	4.8/5.2		
	5.2	提升速度 满载/空载 Lifting speed, full - load/no - load	mm/s	20/25	17/22		
	5.3	下降速度 满载/空载 Lowering speed, full - load/no - load	mm/s	50/40	50/30		
	5.4	最大爬坡度 满载/空载 Maximum gradeability, full - load/no - load	%	6/16	7/16		
	5.5	行车制动 Service brake	电磁制动 Electromagnetic brake				
电机 Motor	6.1	驱动电机功率 S2 60min Drive motor power S2 60min	kW	0.65	0.75		
	6.2	提升电机功率 S3 10 % Lifting motor power S3 10 %	kW	0.5	0.8		
	6.3	蓄电池 根据 DIN 43531/35/36 A, B, C 标准 Battery, as per DIN 43531/35/36 A, B, C	/				
	6.4	蓄电池电压, 额定容量 K5 Battery voltage, rated capacity K5	V/Ah	24/20(24/30/24/36)	48/20		
	6.5	蓄电池重量 (+/-5%) Battery weight (+/-5%)	kg	4.6	7.5		
	6.6	根据 VDI 循环的能耗 Energy consumption as per VDI cycle	kWh/h	0.18	0.25		
其它 Others	7.1	驱动控制方式 Drive control mode	直流速度控制 DC speed control				
	7.2	驾驶员耳边噪声水平, 根据 EN12053 驾驶员耳边噪声水平, 根据 EN12053	dBA(A)	<70	<70		

随技术进步, 产品结构、参数等将不断改进, 恕不另行通知, 样本信息与实物略有不符的, 以实物为准。

The continuous improvements of product structure and parameters along with the technologic progress will be made without further notice. In event of any discrepancy between brochure information and real product, the real product shall prevail.

满载 | 空载 (2.0T款)
7% | 16%
7% under full-load condition
16% under no-load condition
1.5T满载爬坡6%
6% gradeability under full-load condition for 1.5T model

额定载重2000kg的情况下可以爬坡7%, 空载爬坡16%, 灵活操作更自由。

The gradeability is 7% under 2,000kg rated load condition and is 16% under no-load condition to ensure more free operating flexibility.



电动托盘搬运车 ▼ Electric Pallet Truck

步行式托盘搬运车——XCC-PW20

Walkie Pallet Truck - XCC-PW20



产品特点: Best-selling

功率强劲的进口免维护交流电机,加上进口变速箱、制动器和驱动轮,使整车性能更加高效和可靠,降低了运行成本。无论是平稳加速还是快速加速,交流驱动系统都能展现的淋漓尽致。

The powerful imported maintenance-free AC motor works with imported transmission, brake, and drive wheels to realize higher efficiency and reliability and reduce the operating cost of the machine. No matter the steady acceleration or the haste acceleration, the AC drive system can play the best performance.

长手柄的设计使操作者在高效工作的同时,和车体保持一定的安全距离,并具有比短手柄更小的操纵力。

The long handle design enables the operator to maintain a certain safe distance during high-efficiency operations and incorporates smaller operating force than the short handle design.

控制器IP54的防护等级可以有效抵御灰尘和飞溅的水滴,竖直布置的交流驱动电机和刹车系统使得在恶劣的工作环境下也不受影响。The IP54 protection grade of the controllers can effectively withstand the dusts and splashing water drops. The vertically arranged AC drive motor and brake system is resistant to the influences under severe working environments.

选配侧拉电池,可以通过拖车实现快速更换,满足操作者多班次操作车辆。

The optional side-pull battery can allow the quick replacement with the use of tow tractor to meet the multi-shift operation needs of the operator.

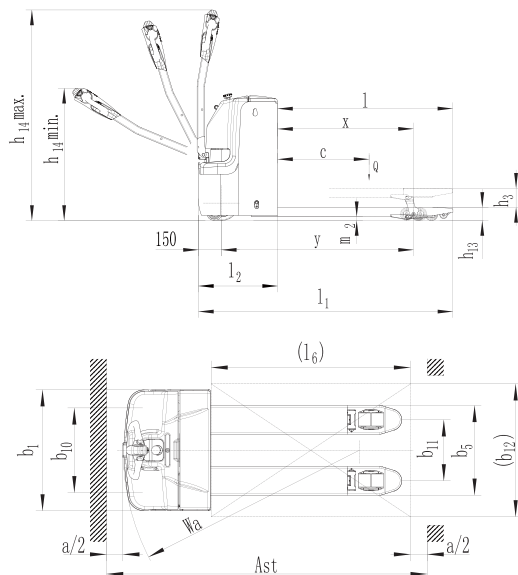

工业车辆参数表 Industrial vehicle specification				
特性 Characteristics	1.1	型号 Model	XCC -PW20	
	1.2	驱动方式 Drive mode	电动 Electric	
	1.3	操作方式(手动, 步行, 站驾, 坐驾, 拣选) Operating mode (Manual, walkie, stand-on, sit-on, and order picking)	步行式 Walkie type	
	1.4	额定载荷能力 Rated load capacity	Q(t)	2.0
	1.5	载荷中心距 Center distance of load	c(mm)	600
	1.6	前悬距 Front overhang	x(mm)	892
	1.7	轴距 Wheelbase	y(mm)	1327
重量 Weights	2.1	含蓄电池时自重 Dead weight with battery	kg	535
	2.2	满载时轮子负荷, 驱动侧/承重侧 Full-load wheel load, drive/load - carrying end	kg	855/1680
	2.3	空载时轮子负荷, 驱动侧/承重侧 No-load wheel load, drive/load - carrying end	kg	415/120
轮子、底盘 Wheels and chassis	3.1	轮胎(实心橡胶, 超弹性体, 充气胎; 聚氨酯胎) Tires (Solid rubber tires, hyperelastic tires, air inflated tires, and polyurethane tires)		聚氨酯轮 Polyurethane wheels
	3.2	前轮规格 Front wheel specification	Øxw(mm)	Ø230×70
	3.3	后轮规格 Rear wheel specification	Øxw(mm)	Ø84×84
	3.4	稳定轮尺寸 Stabilizing wheel size	Øxw(mm)	Ø100×40
	3.5	轮子数量 前/后 (X=驱动轮) Number of wheels, front/rear (X=drive wheel)		1×+2/4
	3.6	前轮轮距 Front wheel tread	b10(mm)	510
	3.7	后轮轮距 Rear wheel tread	b11(mm)	337/512
基本尺寸 Basic dimensions	4.1	提升高度 Lifting height	h3(mm)	120
	4.2	作业时手柄高度, 最小/最大 Handle height during operations, minimum/maximum	h14(mm)	820/1335
	4.3	货叉降低时高度 Height with forks lowered	h13(mm)	85
	4.4	总体长度 Overall length	l1(mm)	1735
	4.5	车体长度 Body length	l2(mm)	595
	4.6	总体宽度 Overall width	b1(mm)	729
	4.7	货叉尺寸 Fork size	s/e/l(mm)	60/17 3/1150
	4.8	货叉外宽 Outer width of forks	b5(mm)	540/685
	4.9	最小离地间隙 Minimum ground clearance	m2(mm)	25
	4.10	工作通道宽度 1000×1200 托盘 (1200 跨货叉放置) Working aisle width for pallets 1,000×1,200 crosswise	Ast(mm)	2315
	4.11	工作通道宽度 800×1200 托盘 (1200 沿货叉放置) Working aisle width for pallets 800×1,200 lengthwise	Ast(mm)	2205
	4.12	转弯半径 Turning radius	Wa(mm)	1490
性能 Performances	5.1	行驶速度 满载/空载 Traveling speed, full-load/no-load	km/h	5.7/6.0
	5.2	提升速度 满载/空载 Lifting speed, Full-load/no-load	mm/s	22/30
	5.3	下降速度 满载/空载 Lowering speed, full-load/no-load	mm/s	35/3.5
	5.4	最大爬坡能力 满载/空载 Maximum gradeability, full-load/no-load	%	8/1.5
电机 Motor	6.1	行车制动 Service brake		电磁制动 Electromagnetic brake
	6.2	驱动电机功率 Drive motor power	kW	1.3
	6.3	提升电机功率 Lifting motor power	kW	0.8
	6.4	蓄电池 根据 DIN 43531/35/36A, B, C 无标准 Battery, as per DIN 43531/35/36 A, B, C, no standard		2PzS
	6.5	蓄电池电压/容量 Battery voltage/capacity	V/Ah	210
	6.5	蓄电池重量 Battery weight	kg	215
	6.6	能耗 (VDI 循环) Energy consumption (VDI cycle)	kWh/h	0.39
其它 Others	7.1	驱动控制 方式 Drive control mode		交流速度控制 AC speed control
	7.2	驾驶员耳边噪声水平根据 EN12053 dB(A) Driver's parotic noise level, as per EN12053 dB(A)	dB(A)	69

随技术进步, 产品结构、参数等将不断改进, 恕不另行通知, 样本信息与实物略有不符的, 以实物为准。

The continuous improvements of product structure and parameters along with the technologic progress will be made without further notice. In event of any discrepancy between brochure information and real product, the real product shall prevail.

电动托盘搬运车 ▼ Electric Pallet Truck

站驾式托盘搬运车——XCC-P20/P25 Walkie Pallet Truck - XCC-P20/P25



产品特点: Best-selling

全系列配置进口交流驱动电机、齿轮箱和电磁控制器，车辆速度高达8km/h。

The whole series is equipped with imported AC drive motor, gearbox, and electromagnetic controller, with the machine speed up to 8km/h.

一体式的踏板和防护臂以及继的车体内部结构，使搬运车的整车长度最大限度的缩短，做到了行业内较小的转弯半径。浮动结构的踏板使操作更加舒适。

The integral footplates and protective arms and the all-new body internal structure minimize the overall length of the pallet truck and realize the minimum turning radius within the industry. The footplates in floating structure realize higher operating comfort.

更加符合人体工程学的控制手柄，通过可靠的控制系统和非接触式的起升下降翘板开关设置，提升操纵舒适感的同时，大幅延长了手柄的使用寿命。The handle better conforms to the ergonomic principles and improves the operating comfort while remarkably prolong their lives by means of reliable control system and non-contact lifting/lowering rocker switch settings.

选配密码锁，可以手动录入密码，也支持刷卡启动，大大简化了授权操作的流程，满足多人操作需求。选配内置充电器，对于使用强度不大的工况更加简化了充电工作。

The optional password lock allows the start by manually inputted password or card swiping to remarkably simplify the authorization procedure and meet the multi-operator operation needs. The optional built-in charger better simplifies the charging operation under the working conditions with low operating intensity.

选配侧拉电池，可以通过拖车实现快速更换，满足操作者多班次操作车辆。The optional side-pull battery can allow the quick replacement with the use of tow tractor to meet the multi-shift operation needs of the operator.

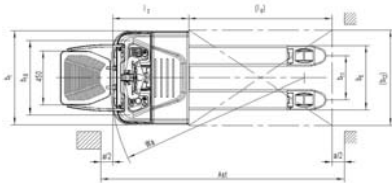
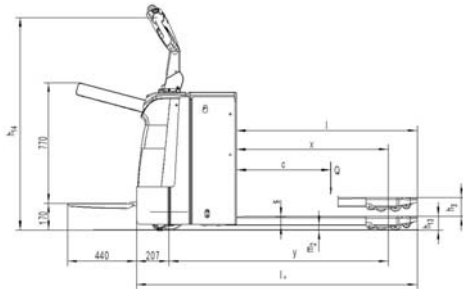

工业车辆参数表 Industrial vehicle specification				
特性 Characteristics	1.1	型号 Model		XCC-P20 XCC-P25
	1.2	动力/电动机、柴油、汽油、液化石油气、电气 Power system (Motor, diesel, gasoline, LPG, or electric)		电池 Battery
	1.3	操作方式 Operating mode		站驾式 Stand-on type
	1.4	额定载荷能力 Rated load capacity	Q(t)	2.0 2.5
	1.5	载荷中心距 Center distance of load	c(mm)	600 600
	1.6	前悬距 Front overhang	x(mm)	892 ¹⁾ 892 ¹⁾
	1.7	轴距 Wheelbase	y(mm)	1330 ²⁾³⁾ 1435 ¹⁾
重量 Weights	2.1	自重(包括蓄电池) Dead weight (including battery)	kg	620 770
	2.2	满载时桥负荷, 驱动侧/承重侧 Full-load axle load, drive/load-carrying end	kg	1110/1510 1370/1900
	2.3	空载时桥负荷, 驱动侧/承重侧 No-load axle load, drive/load-carrying end	kg	500/120 610/160
轮子、底盘 Wheels and chassis	3.1	轮子 Wheels		聚氨酯轮(PU) Polyurethane wheels (PU)
	3.2	轮子尺寸 驱动侧 Wheel size, drive end	Øxw(mm)	Ø230×70
	3.3	轮子尺寸 承重侧 Wheel size, load-carrying end	Øxw(mm)	Ø84×84
	3.4	稳定轮尺寸 Stabilizing wheel size	Øxw(mm)	Ø100×40
	3.5	轮子数量(X=驱动轮) 驱动侧/承重侧 Number of wheels (X=drive wheel), drive/load-carrying end		1×2+4
	3.6	轮距(前面) 驱动侧 Wheel tread (Front), drive end	b10(mm)	540
	3.7	轮距(后面) 承重侧 Wheel tread (Rear), load-carrying end	b11(mm)	367/512
基本尺寸 Basic dimensions	4.1	提升高度 Lifting height	h3(mm)	120
	4.2	作业时手柄高度, 最小/最大 Handle height during operations, minimum/maximum	h14(mm)	950/1350
	4.3	货叉降低时高度 Height with forks lowered	h13(mm)	85
	4.4	总体长度 Overall length	l1(mm)	1790 ²⁾³⁾ 1895
	4.5	车体长度 Body length	l2(mm)	640 ²⁾³⁾ 745 ³⁾
	4.6	总体宽度 Overall width	b1(mm)	790
	4.7	货叉尺寸 Fork size	s/e/l(mm)	55/173/1150
	4.8	货叉外宽 Outer width of forks	b5(mm)	540/685
	4.9	最小离地间隙 Minimum ground clearance	m2(mm)	30
	4.10	工作通道宽度1000×1200托盘(1200跨货叉放置) Working aisle width for pallets 1,000×1,200 crosswise	Ast(mm)	2400 ²⁾³⁾ 2505 ³⁾
4.11	工作通道宽度800×1200托盘(1200沿货叉放置) Working aisle width pallets 800×1,200 lengthwise	Ast(mm)	2290 ²⁾³⁾ 2395 ³⁾	
4.12	转弯半径 Turning radius	Wa(mm)	1585 ²⁾³⁾ 1690 ³⁾	
性能 Performances	5.1	行驶速度 满载/空载 Traveling speed, full-load/no-load	km/h	7.5/8.0 6.0/7.0
	5.2	提升速度 满载/空载 Lifting speed, full-load/no-load	mm/s	25/30 35/45
	5.3	下降速度 满载/空载 Lowering speed, full-load/no-load	mm/s	30/25 45/50
	5.4	最大爬坡能力 满载/空载 Maximum gradeability, full-load/no-load	%	8/15
	5.5	行车制动 Service brake		电磁制动 Electromagnetic brake
电机 Motor	6.1	驱动电机功率 Drive motor power	kW	1.4
	6.2	提升电机功率 Lifting motor power	kW	0.8 2.2
	6.3	电池, DIN标准43531/35/36A,B,C, 不是Battery, as per DIN 43531/35/36A, B, C, none	/	/
	6.4	蓄电池电压/容量(8小时放电容量) Battery voltage/capacity (8h discharge capacity)	V/Ah	24/160-210 24/270-350
	6.5	蓄电池重量(+/-5%) Battery weight (+/-5%)	kg	155-200 285
	6.6	根据VDI循环的能耗 Energy consumption as per VDI cycle	kWh/h	0.36 0.90
其它 Others	7.1	驱动控制方式 Drive control mode		交流速度控制 AC speed control
	7.2	驾驶员耳边噪声水平 Driver's parotic noise level	dB(A)	69

1) 承重轮在最低位置: +65mm; 2) 侧拉电瓶尺寸: +30mm; 3) 踏板放下尺寸+440mm

1) Load-carrying wheels at lowest position: +65mm; 2) Side-pull battery size: +30mm; 3) Lowered footplate size: +440mm.

搬运车系列的额定载荷为2000kg和2500kg, 车辆即使在多班次工作的情况下也能保证高效率。由于速度快, 并且可选配

多种电池, 包括锂电池, 所以可以大大提高工作效率。多功能应用灵活的托盘搬运车是满足您多种需求的好帮手。

The rated load capacity is 2,000kg and 2,500kg for pallet truck series so that the high efficiency can be guaranteed even under the multi-shift operation mode. Thanks to the high speed and the diversified optional batteries (including lithium battery), the working efficiency can be remarkably promoted. This multifunctional and flexible pallet truck is a good helper to meet your diversified needs.

电动托盘堆垛车 ▼ Electric Pallet Truck

步行式托盘堆垛车——XCS-PW12(经济版)

Walkie pallet stacker - XCS-PW12 (Economy version)

产品特点: Best-selling

电磁控制的升降系统, 确保每次堆垛作业可以准确定位。高升程的情况下, 电磁控制的升降可以表现的更完美。

The electromagnetically controlled lifting system guarantees the accurate positioning during every stacking operation. The electromagnetically controlled lifting and lowering functions can be manifested more perfectly under high lifting height condition.

长手柄的设计使操作者在高效工作的同时, 和车体保持一定的安全距离, 并具有比短手柄更小的操纵力。长手柄中置的四轮设计, 使得操作者有更好的观察托盘的视野。

The long handle design enables the operator to maintain a certain safe distance during high-efficiency operations and incorporates smaller operating force than the short handle design. The four-wheel design with middle long handle enables the operator to have a better observation vision on the pallets.

使用数字信号的CAN-BUS技术不仅减少了接线的数量, 简化了查找和解决故障的复杂性, 同时提高了系统的可靠性, 与模拟信号相比零件寿命更长。

The digital signal CAN-BUS technology is applied to reduce the wiring quantity, simplify the lookup and troubleshooting complexity, improve the system reliability, and realize longer parts lives compared with analog signal counterparts.

XCS-PW12(经济版) 标准配置

Standard configuration of XCS-PW12 (Economy version)

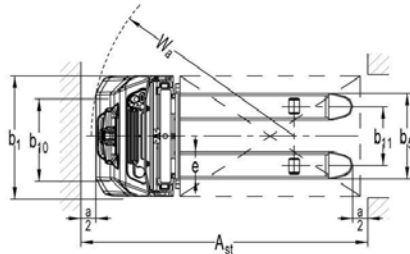
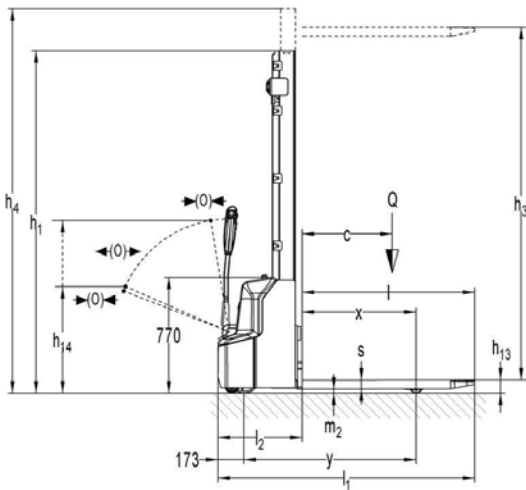

工业车辆参数表 Industrial vehicle specification				
特性 Characteristics	1.1	型号 Model	XCS - PW12 经济款 XCS - PW12 Economy version	
			1600	360 0
特性 Characteristics	1.2	动力 (电动, 柴油, 汽油, 液化石油气, 电气) Power system (Motor, diesel, gasoline, LPG, or electric)	电池 Battery	
	1.3	操作模式 (手动式, 步行式, 站驾式, 座驾式, 站立和/或骑行) Operating mode (Manual, walkie, stand on, sit on, stand and/or riding)	步行式 Walkie type	
	1.4	额定载重能力 Rated load capacity	Q(t)	
	1.5	载荷中心距 Center distance of load	c(mm)	
	1.6	前悬距 Front overhang	x(mm)	
	1.7	轴距 Wheelbase	y(mm)	
	重量 Weights	2.1	自重 (包括蓄电池) Dead weight (including battery)	kg
2.2		满载时桥负荷 - 驱动侧 / 承重侧 Full - load axle load, drive/load - carrying end	k g	510/1210
2.3		空载时桥负荷 - 驱动侧 / 承重侧 No - load axle load, drive/load - carrying end	kg	380/140
车轮 Wheels	3.1	轮胎 (橡胶轮胎, 聚氨酯轮胎, 充气轮胎, 聚氨酯轮胎) Tires (Rubber tires, hyperelastic tires, air inflated tires, and polyurethane tires)	聚氨酯轮胎 Polyurethane wheels	
	3.2	轮子尺寸 - 驱动侧 Wheel size, drive end	Oxw(mm)	Ø210*70
	3.3	轮子尺寸 - 承重侧 Wheel size, load - carrying end	Oxw(mm)	Ø84*93
	3.4	转向轮尺寸 Steering wheel size	Oxw(mm)	Ø100*50
	3.5	轮子数量 (X = 驱动轮) 驱动侧 / 承重侧 Number of wheels (X = drive wheel), drive/load - carrying end		1 × 1/ 2
尺寸 Dimensions	3.6	轮距 (前面) 驱动侧 Wheel tread (Front), drive end	b10(mm)	550
	3.7	轮距 (后面) 承重侧 Wheel tread (Rear), load - carrying end	b11(mm)	400/515
	4.1	降低时门架高度 Mast height during lowering	h1(mm)	1930
	4.2	自由提升高度 Free lifting height	h2(mm)	1514
	4.3	提升高度 Lifting height	h3(mm)	1514
	4.4	门架可延伸高度 Mast extensible height	h4(mm)	1930
	4.5	手柄在最小 / 最大驱动位置时的高度 Height of handle at minimum/maximum drive position	h14(mm)	710/1150
	4.6	降低时高度 Height during lowering	h13(mm)	86
	4.7	总体长度 Overall length	l1(mm)	1710
	4.8	距离叉面长度 Length to fork face	l2(mm)	560
	4.9	总体宽度 Overall width	b1(mm)	800
	4.10	叉叉尺寸 Fork size	s/e(mm)	60/180/1150
	4.11	叉叉臂间的距离 Distance between fork arms	b5(mm)	570/685
	4.12	轴距中心距地间隙 Ground clearance of wheelbase center	m 2(mm)	30
	4.13	托盘 1000×1200 交叉时通道宽度 Aisle width for pallets 1,000 × 1,200 crosswise	Ast(mm)	2197
4.14	托盘 800×1200 交叉时通道宽度 Aisle width for pallets 800 × 1,200 crosswise	Ast(mm)	2145	
4.15	转弯半径 Turning radius	Wa(mm)	1350	
性能 Performances	5.1	行驶速度 满载 / 空载 Traveling speed, full - load/no - load	km/h	4.2/4.5
	5.2	提升速度 满载 / 空载 Lifting speed, Full - load/no - load	mm/s	110/160
	5.3	下降速度 满载 / 空载 Lowering speed, full - load/no - load	mm/s	130/110
	5.4	最大爬坡能力 满载 / 空载 Maximum gradeability, full - load/no - load	%	5/10
	5.5	行车制动 Service brake		电磁制动 Electromagnetic brake
电机 Motor	6.1	驱动电机功率最小 Minimum drive motor power S2 60	kW	0.65
	6.2	提升电机功率 Lifting motor power S3 7.5% S3 7.5%	kW	2.2
	6.3	蓄电池, 根据 DIN 43531/35/36 A, B, C 标准 Battery, as per DIN 43531/35/36 A, B, C 标准		no
	6.4	蓄电池电压, 额定容量 K5 Battery voltage, rated capacity K5	V/Ah	2 × 12/85 ¹⁾
	6.5	蓄电池重量 Battery weight	kg	2 × 27
	6.6	能量损耗 根据 VDI 循环标准 Energy consumption, as per VDI cycle standard	kWh/h	0.8
其它 Others	7.1	驱动控制方式 Drive control mode		DC
	7.2	驾驶员耳边噪声水平 dB(A)		<70

1) 选配 : 2) 2 × 12/106 (铅酸), 24/60 (锂电)
1) Optional: 2) 2 × 12/106 (Lead - acid), 24/60 (Lithium)

随技术进步, 产品结构、参数等将不断改进, 恕不另行通知。样本信息与实物略有不符的, 以实物为准。
The continuous improvements of product structure and parameters along with the technologic progress will be made without further notice. In event of any discrepancy between brochure information and real product, the real product shall prevail.

电动托盘堆垛车 ▼ Electric Pallet Truck

步行式托盘堆垛车——XCS-PW12/16/20 Walkie pallet stacker - XCS-PW12/16/20



产品特点: Best-selling

电磁控制的升降系统, 确保每次堆垛作业可以准确定位。高升降的情况下, 电磁控制的升降可以表现的更完美。

The electromagnetically controlled lifting system guarantees the accurate positioning during every stacking operation. The electromagnetically controlled lifting and lowering functions can be manifested more perfectly under high lifting height condition. Long handle design enables operator to maintain a certain safe distance during high-efficiency operations and incorporates smaller operating force than the short handle design. The four-wheel design with middle long handle enables the operator to have a better observation vision on the pallets.

The long handle design enables the operator to maintain a certain safe distance during high-efficiency operations and incorporates smaller operating force than the short handle design. The four-wheel design with middle long handle enables the operator to have a better observation vision on the pallets. 使用数字信号的CAN-BUS技术不仅减少了接线的数量, 简化了查找和解决故障的复杂性, 同时提高了系统的可靠性, 与模拟信号相比零件寿命更长。

The digital signal CAN-BUS technology is applied to reduce the wiring quantity, simplify the lookup and troubleshooting complexity, improve the system reliability, and realize longer parts lives compared with analog signal counterparts.

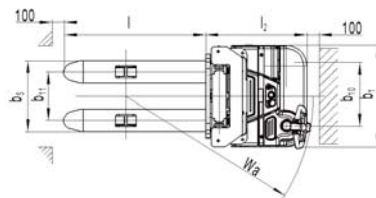
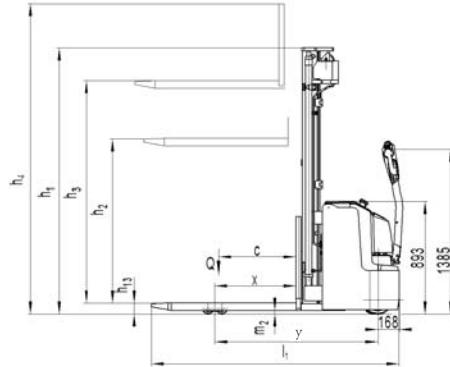

工业车辆参数表 Industrial vehicle specification					
		XCS -PW12	XCS -PW16	XCS -PW16	XCS -PW20
特性 Characteristics	1.1 型号 Model				
	1.2 动力 (电动, 柴油, 汽油, 液化石油气, 电气) Power system (Motor, diesel, gasoline, LPG, or electric)	电池 Battery			
	1.3 操作方式 (手动式, 步行式, 站驾式, 座驾式, 拖运式) Operating mode (Manual, walkie, stand-on, sit-on, and order-picking)	步行式 Walkie type			
	1.4 额定载荷能力 Rated load capacity	Q(0)	1.2	1.6	2.0
	1.5 载向中心距 Carrier distance of load	c(mm)	600		
	1.6 前悬距 Front overhang	x(mm)	647	637	647
	1.7 轴距 Wheelbase	y(mm)	1248		
重量 Weights	2.1 重量 (包括蓄电池) Weight (including battery)	kg	1007	1150	1340
	2.2 满载时桥负荷, 驱动侧 Full-load axle load, drive/load	kg	684/1523	735/1610	930/2010
	2.3 空载时桥负荷, 驱动侧 No-load axle load, drive/load	kg	610/397	720/430	850/490
车轮 Wheels	3.1 轮胎 (橡胶, 聚氨酯, 弹性体, 气胎, 聚氨酯) Tires (Rubber tires, hyperelectric tires, air inflated tires, and polyurethane tires)	聚氨酯轮 Polyurethane wheels			
	3.2 轮子尺寸 驱动侧 Wheel size, drive end	Øxw(mm)	Ø230×70		
	3.3 轮子尺寸 承重侧 Wheel size, load-carrying end	Øxw(mm)	Ø84×70		
	3.4 转向轮 尺寸 Steering wheel size	Øxw(mm)	Ø150×54		
	3.5 轮子数量 (X=驱动轮) 驱动侧 / 承重侧 Number of wheels (X=drive wheel), drive/load-carrying end	1×1/4			
	3.6 轮距 (前部) 驱动侧 Wheel tread (Front), drive end	b10(mm)	522		
	3.7 轮距 (后面) 承重侧 Wheel tread (Rear), load-carrying end	b11(mm)	390/505		
尺寸 Dimensions	4.1 降低时门架高度 Mast height during lowering	h1(mm)	2308	2108	2108
	4.2 自由提升高度 Free lifting height	h2(mm)	1760	1520	1520
	4.3 提升高度 Lifting height	h3(mm)	3530	4530	4530
	4.4 门架可延伸高度 Mast extensible height	h4(mm)	4088	5088	5088
	4.5 手柄在最小/最大驱动位置时的高度 Height of handle at minimum/maximum drive position	h14(mm)	850/1385		
	4.6 降低时高度 Height during lowering	h13(mm)	90		
	4.7 总体长度 Overall length	l1(mm)	1919	1929	1964
	4.8 距叉面长度 Length to fork face	l2(mm)	769	779	814
	4.9 总体宽度 Overall width	b1(mm)	820		
	4.10 叉叉尺寸 Fork size	s/e/l(mm)	60/180/1150		
性能 Performances	4.11 叉叉臂间的距离 Distance between fork arms	b5(mm)	570/685		
	4.12 轴心距地面高度 Ground clearance of wheelbase center	m2(mm)	28	28	23
	4.13 托盘 1000×1200 交叉时通道宽度 Aisle width for pallets 1000 × 1200 crosswise	Ast(mm)	2336	2336	2406
	4.14 托盘 800×1200 交叉时通道宽度 Aisle width for pallets 800 × 1200 crosswise	Ast(mm)	2323	2323	2393
	4.15 转弯半径 Turning radius	Wa(mm)	1440	1510	1640
	5.1 行驶速度 满载 / 空载 Traveling speed, full-load / no-load	km/h	6.0/6.0	5.7/6.0	5.4/6.0
	5.2 提升速度 满载 / 空载 Lifting speed, Full-load / no-load	mm/s	90/140	130/200	130/200
	5.3 下降速度 满载 / 空载 Lowering speed, full-load / no-load	mm/s	250/200	280/230	280/230
	5.4 最大爬坡能力 Maximum gradeability, full-load / no-load	%	6/12	6/12	6/10
	5.5 行车制动 Service brake	电磁制动 Electromagnetic brake			
电机 Motor	6.1 驱动电机功率 最小 Minimum drive motor power S2	kW	1.3	1.3	1.7
	6.2 提升电机功率 Lifting motor power S3 10 % S3 10 %	kW	1.5	3.2	3.2
	6.3 蓄电池, 根据 A, B, C 标准 Battery, as per DIN 43531/35/36 A, B, C	2VBS	3VBS		
	6.4 蓄电池电压, 额定容量 Battery voltage, rated capacity K5	V/Ah	24/180	2/270	24/350
	6.5 蓄电池重量 Battery weight	kg	175	230	288
	6.6 能量消耗 根据 VDI 标准 Energy consumption, as per VDI cycle standard	kWh/h	0.95	1.59	1.7
其它 Others	7.1 驱动控制方式 Drive control mode	交流速度控制 AC speed control			
	7.2 驾驶员耳旁噪声水平 Driver's parotic noise level	dB(A)	<70		

随技术进步, 产品结构、参数等将不断改进, 恕不另行通知。样本信息与实物略有不符, 以实物为准。

The continuous improvements of product structure and parameters along with the technological progress will be made without further notice. In event of any discrepancy between brochure information and real product, the real product shall prevail.

电动托盘堆垛车 ▼ Electric Pallet Truck

步行式托盘堆垛车——XCS-PW15(经济版)

Walkie pallet stacker - XCS-PW15 (Economy version)

产品特点: Best-selling

XCS-PW15托盘堆高车,是一款经济型长手柄堆高车,额定载重1.5吨,起升高度1600-3600mm,满足客户对经济性、搬运效率、安全性不断提高的需求。

XCS-PW15 pallet stacker is an economic long-handle stacker, with rated load capacity at 1.5t and lifting height at 1,600-3,600mm, to meet the customers' continuously increasing demands of economy, handling efficiency, and safety.

此款叉车操作灵活,经济实用,能充分满足客户的要求。结构紧凑,转弯半径比常规车小,更适合堆垛通道小的仓库运作。This stacker features flexible operations and high economy and practicability and can sufficiently meet the customers' needs. Featuring compact structure and smaller turning radius than conventional counterparts, it's more suitable for the operations in the warehouses with small stacking aisles.

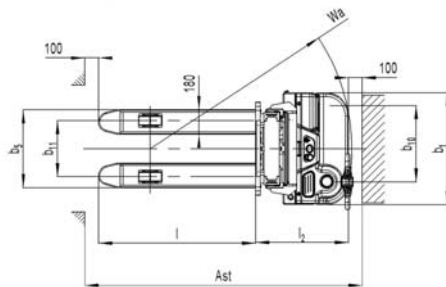
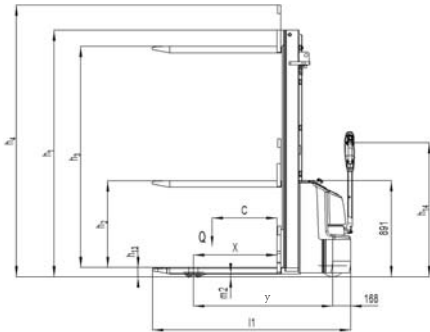

工业车辆参数表 Industrial vehicle specification					
特性 Characteristics	1.1	型号 Model	XCS -PW15 经济款 XCS -PW1 5 (Economy version)		
	1.2	动力(电动,柴油,汽油,液化石油气,电气) Power system (Motor, diesel, gasoline, L PG, or electric)	1600	3600	
	1.3	驾驶方式(手动式,步行式,站驾式,座驾式,拣选式) Driving mode (Manual, walkie, stand -on, sit -on, and order picking)	电池 Battery		
	1.4	额定载荷能力 Rated load capacity	Q(t)	1.5	
	1.5	载荷中心距 Center distance of load	c(mm)	600	
	1.6	前悬距 Front over hang	x(mm)	770	
	1.7	轴距 Wheelbase	y(mm)	1258	1283
重量 Weights	2.1	重量(包括蓄电池) W eight (including battery)	kg	641	782
	2.2	满载时桥负荷,驱动侧 /承重侧 Full -load axle load, drive/load -carrying end	kg	677/1464	722/1560
	2.3	空载时桥负荷,驱动侧 /承重侧 No -load axle load, drive/load -carrying end	kg	446/195	544/238
车轮	3.1	轮胎(橡胶胎,高性能弹性体,气胎胎,聚氨酯胎) Tires (Rubber tires, hyperelastic tires, air inflated tires, and polyurethane tires)	聚氨酯轮 Polyurethane wheels		
	3.2	前轮尺寸 Front wheel size	Øxw(mm)	Ø210×70	
	3.3	后轮尺寸 Rear wheel size	Øxw(mm)	Ø80×70	
	3.4	稳定轮(尺寸) Stabilizing wheel (Size)	Øxw(mm)	Ø100×50	
	3.5	轮子数量(前/后) Number of wheels, front/rear		1×1/14	
	3.6	轮距(前面) Wheel tread (Front)	b10(mm)	557	
	3.7	轮距(后面) Wheel tread (Rear)	b11(mm)	410/525	
尺寸	4.1	门架缩回时高度 Height with masts retracted	h 1(mm)	1978	2280
	4.2	自由提升高度 Free lifting height	h2(mm)	1510	78
	4.3	提升高度 Lifting height	h3(mm)	1515	3515
	4.4	门架可延伸高度 Mast extensible height	h4(mm)	1985	4005
	4.5	手柄在最小/最大驱动位置时的高度 Height of handle at minimum/maximum drive position	h14(mm)	710/1245	
	4.6	货叉降低时高度 Height with forks lowered	h13(mm)	85	
	4.7	总体长度 Overall length	l1(mm)	1806	1830
	4.8	车体长度 Body length	l2(mm)	656	681
	4.9	总体宽度 Overall width	b1(mm)	820	
	4.10	货叉尺寸 Fork size	s/e/l(mm)	60/180/1150	
	4.11	货叉臂间的距离 Distance between fork arms	b 5(mm)	570/685	
	4.12	轴距中心距地间隙 Ground clearance of wheelbase center	m2(mm)	25	
	4.13	托盘 1000×1200 交叉时通道宽度 Aisle width for pallets 1,000×1,200 crosswise	Ast(mm)	2293	2317
	4.14	托盘 800×1200 交叉时通道宽度 Aisle width for pallets 800×1,200 crosswise	Ast(mm)	2237	2261
	4.15	转弯半径 Turning radius	Wa(mm)	1450	1474
性能 Performances	5.1	行驶速度 满载 /空载 Traveling speed, full -load/no -load	km/h	4.4/4.7	
	5.2	提升速度 满载 /空载 Lifting speed, Full -load/no -load	mm/s	105/170	
	5.3	下降速度 满载 /空载 Lowering speed, full -load/no -load	mm/s	126/ 126	
	5.4	最大爬坡能力 满载 /空载 Maximum gradeability, full -load/no -load	%	5/10	
	5.5	行车制动 Service brake	电磁制动 Electromagnetic brake		
电机 Motor	6.1	驱动电机功率 Drive motor power	kW	0.75	
	6.2	提升电机功率 S3 7.5% Lifting motor power S3 7.5%	kW	2.2	
	6.3	蓄电池,根据 DIN 43531/35/3 Battery, as per DIN 43531/35/36 A, B, C 标准	no		
	6.4	蓄电池电压,额定容量 K5 Battery voltage, rated capacity K5	V/Ah	4×12/64	
	6.5	蓄电池重量 Battery weight	kg	4×20	
	6.6	能量消耗 根据 VDI 循环标准 Energy consumption, as per VDI cycle standard	kWh/h	0.5	
其它 Others	7.1	驱动控制方式 Drive control mode	直流速度控制 DC speed control		
	7.2	驾驶员耳边噪声水平 Driver's parotic noise level	dB(A)	<70	

随技术进步,产品结构、参数等将不断改进,恕不另行通知。样本信息与实物略有不符的,以实物为准。

The continuous improvements of product structure and parameters along with the technologic progress will be made without further notice. In event of any discrepancy between brochure information and real product, the real product shall prevail.

电动托盘堆垛车 ▼ Electric Pallet Truck

站驾式托盘堆垛车——XCS-P12/15

Sit-on pallet stacker - XCS-PW12/15

产品特点: Best-selling



全系列配置交流驱动电机、齿轮箱和电磁控制器，车辆速度达6km/h。

The whole series is equipped with AC drive motor, gearbox, and electromagnetic controller, with the machine speed up to 6km/h.

更加符合人体工程学的控制手柄，通过可靠的控制系统和非接触式的起升下降翘板开关设置，提升舒适感的同时，大幅延长了手柄的使用寿命。

The handle better conforms to the ergonomic principles and improves the operating comfort while remarkably prolong their lives by means of reliable control system and non-contact lifting/lowering rocker switch settings.

采用进口驱动控制器和转向控制器，为客户提供可靠灵活的高性能控制系统方案。

The imported drive controller and steering controller are applied to provide reliable and flexible high-performance control system scheme for the customers.

选配比例确保了货叉在起升下降过程中的准确定位，并且升降的加速度更加流畅，为易碎物品的堆垛搬运操作提供了可靠的保障性。

The optional proportional lifting system guarantees the accurate positioning of forks during lifting and lowering, realizes smoother lifting/lowering acceleration and deceleration, and provides reliable safeguard for the stacking and handling operations of fragile



钥匙开关、急停开关、电量表

Key switch, emergency stop switch, and power level gauge



手柄采用CAN-BUS技术，符合人体工程学，左右手都可操作

With the application of CAN-BUS technology, the handle conforms to ergonomic principles and is operable to both left and right hands.



可存放保鲜膜、文档和写字板等物品的存储区域，适合长时间操作

Storage area for storage of articles such as preservative film, documents, and word pad



高性能的3PzS(4PzS) DIN标准电瓶，适合长时间操作

The high-performance 3PzS (4PzS) DIN standard battery is suitable for long-time operations.

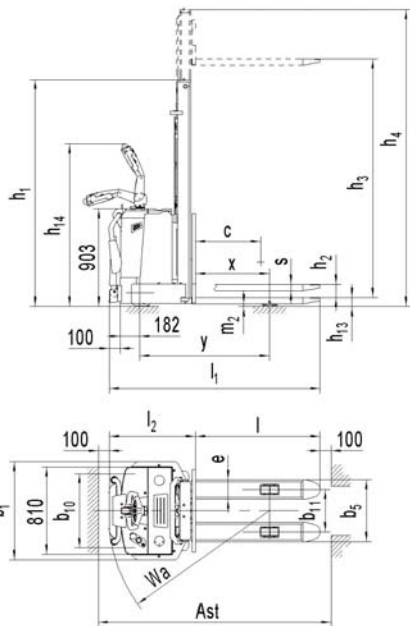

工业车辆参数表 Industrial vehicle specification							
特性 Characteristics	1.1	型号 Model	XCS - P12				XCS - P15
	1.2	动力系统: 柴油、汽油、液化石油气、电动机 Power system (Motor, diesel, gasoline, LPG, or electric)	电动 Electric				电动 Electric
重量 Weights	1.3	驾驶模式: 步行式、站驾式、叉架式、牵引式、拖车式 Driving mode (Manual, walkie, stand - on, sit under pushing)	步行式 / 站驾式 Walkie type/pedal type				步行式 / 站驾式 type/pedal type
	1.4	额定载重能力 Rated load capacity	Q(t)				1.2
	1.5	载荷中心距 Center distance of load	c(mm)				600
	1.6	前悬距 Front overhang	x(mm)				684
	1.7	轴距 Wheelbase	y(mm)				1196
	2.1	重量 (包括蓄电池) Weight (including battery)	kg	930	945	960	975
	2.2	满载时前悬距、驱动轴 / 承重轴 Full load axle load, drive/load - carrying end	kg	820/1310	825/1320	830/1330	835/1340
2.3	空载时前悬距、驱动轴 / 承重轴 No load axle load, drive/load - carrying end	kg	720/210	725/220	730/230	735/240	
轮胎 Wheels	3.1	橡胶轮胎、充气轮胎、实心轮胎、聚氨酯轮胎 Tires (Rubber tires, hypobaric tires, air inflated tires, and polyurethane tires)	聚氨酯轮胎 (Polyurethane wheels)				聚氨酯轮胎 (Polyurethane wheels)
	3.2	轮胎尺寸、驱动轴 Wheel size, drive end	Oxw(mm)	6222-88			6222-88
	3.3	轮胎尺寸、承重轴 Wheel size, load - carrying end	Oxw(mm)	680-70			680-70
	3.4	转向轮尺寸 Steering wheel size	Oxw(mm)	6150-54			6150-54
	3.5	轮胎数量 Number of wheels (X = 驱动轴 / 承重轴, Y = 驱动轴 / 承重轴) X / 承重轴 drive/load - carrying end		1+1+14			1+1+14
3.6	轮胎 (前轴) 驱动轴 Wheel tread (Front drive end)	b10(mm)	686			686	
3.7	轮胎 (后轴) 承重轴 Wheel tread (Rear, load - carrying end)	b11(mm)	390/505			390/505	
尺寸 Size	4.1	降低时门架高度 Mast height during lowering	h1(mm)	1796	1946	2096	2296
	4.2	自由提升高度 Free lifting height	h2(mm)	120			150
	4.3	提升高度 Lifting height	h3(mm)	2519	2819	3119	3519
	4.4	门架可延伸高度 Mast extendible height	h4(mm)	2996	3296	3596	3996
	4.5	手柄最低点 高度 Height of handle at minimum maximum drive position	h14(mm)	985/1420			985/1420
	4.6	降低时高度 Height during lowering	h13(mm)	81			8 1
	4.7	总体长度 Overall length	l1(mm)	1846/1946			1883/1983
	4.8	前叉面长度 Length to fork face	l2(mm)	695/795			733/833
	4.9	总体宽度 Overall width	b1(mm)	912			912
	4.10	叉架尺寸 Fork size	s/e(mm)	60/180/1150			60/180/1150
	4.11	英文臂间的距离 Distance between fork arms	h2(m mm)	570/685			570/685
	4.12	离地中心距 Ground clearance of wheelbase center	m2(mm)	26			21
	4.13	叉架间距 Aisle width for pallets 1000*1200 交叉 1200*1200 crosswise	Ast(mm)	2320/2420			2360/240
	4.14	叉架间距 Aisle width for pallets 800*1200 交叉时 900*1200 crosswise	Ast(mm)	2215/2315			2360/2460
	4.15	转弯半径 Turning radius	Wa(mm)	1400/1500			1440/1540
性能 Performances	5.1	行驶速度 Traveling speed, full - load	km/h	6.0/6.0			6.0/6.0
	5.2	提升速度 Lifting speed, full - load/no - load	mm/s	105/150			105/150
	5.3	下降速度 Lowering speed, full - load/no - load	mm/s	130/110			130/110
	5.4	最大爬坡能力 Maximum gradability, full - load/no - load	%	6/12			6/12
	5.5	行车制动 Service brake		电磁制动 Electromagnetic brake			电磁制动 Electromagnetic brake
电机 Motor	6.1	驱动电机功率最小值 Minimum drive motor power S2 60	kW	1.3			1.3
	6.2	提升电机功率 Lifting motor power S1 7.5	kW	2.2			3.0
	6.3	额定电压、额定电流、额定功率 Rated voltage, rated current, rated power 48V/17.5/36 A 48V/17.5/36 A 48V/17.5/36 A		DIN, B, C None, 3PzS battery cell			无、单体、3PzS
	6.4	蓄电池电压、额定容量 Battery voltage, rated capacity	V/Ah	24/210			24/210
	6.5	蓄电池重量 Battery weight	kg	200			200
	6.6	能量消耗 Energy consumption, as per VDI 2196 standard	kWh	1.4			2.59
其它 Others	7.1	驱动控制方式 Drive control mode		AC 速度控制 AC speed control			AC 速度控制 AC speed control
	7.2	驾驶员耳边噪声水平 Driver's ear noise level	dB(A)	<70			<70

随技术进步，产品结构、参数等将不断改进，恕不另行通知。样本信息与实物略有不符的，以实物为准。

The continuous improvements of product structure and parameters along with the technologic progress will be made without further notice. In event of any discrepancy between brochure information and real product, the real product shall prevail.

电动托盘堆垛车 ▼ Electric Pallet Truck

站驾式托盘堆垛车——XCS-P16/20

Sit-on pallet stacker - XCS-P16/20

产品特点: Best-selling

XCS-P16/20堆垛车系列额定载荷为1600kg和2000kg。

The rated load capacity of XCS-P16/20 stacker series is 1,600kg and 2,000kg.

设计紧凑,整车长度短,转弯半径小,可在狭小空间内操作。

With compact design, short overall length, and small turning radius, it can be used in narrow spaces.

具有全比例升降的液压系统,可实现上升下降过程中的精确定位。

The full-proportional lifting/lowering hydraulic system can realize the accurate positioning during the lifting/lowering.

车辆行驶速度快,且可选配多种电池及锂电池,满足更多客户需求。

This machine features high traveling speed and can be installed with diversified optional battery types and lithium batteries to meet more customer needs.

可以选配侧拉电池,全新专利电瓶锁机构可以确保操作过程中电池不晃动,减小噪音。

It can be installed with optional side-pull battery. The all-new patented battery lock mechanism can eliminate the shaking of the battery and reduce the noise during operations.

可选配密码锁,通过手动输入密码或刷卡启动车辆。

The optional password lock allows the start of machine by manually inputted password or card swiping.



Type XCS-P16		Type XCS-P20	
Mast 5500		Mast 4800	
h3 (mm)	Q (kg)	h3 (mm)	Q (kg)
5500	600 350	4800	1000 700
4800	700 400	4300	1100 800
4300	800 500	3600	1200 900
3600	900 600	3000	1300 1000
3000	1000 700	2600	1400 1100
2600	1200 800	2000	1600 1300
2000	1400 900	1600	1800 1500
1600	1600 1000		
c(mm)	600 700	c(mm)	600 700

注:可根据客户要求要求进行性能订制,具体参数请咨询销售人员。

Note: The performance customization is offered as per customer demands. For detailed specification, please consult with sales personnel.

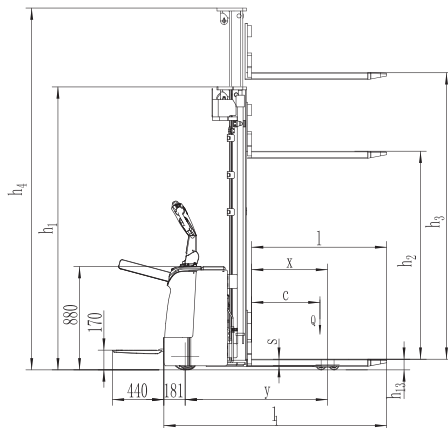
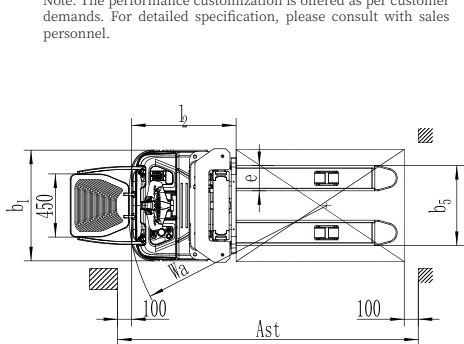

工业车辆参数表 Industrial vehicle specification					
特性 Characteristics	1.1	型号 Model		XCS -P16	XCS -P20
	1.2	动力(电动,柴油,汽油,液化石油气,电气) Power system (Motor, diesel, gasoline, LPG, or electric)		电池 Battery	
	1.3	驾驶方式(手动式,步行式,站驾式,座驾式,骑驾式) Driving mode (Manual, walkie, stand -on, sit -on, and order picking)		步行式/站驾式 Walkie type/stand -on type	
	1.4	额定载荷能力 Rated load capacity	Q(t)	1.6	2.0
	1.5	载荷中心距 Center distance of load	c(mm)	600	
	1.6	前悬距 Front overhang	x(mm)	647	
	1.7	轴距 Wheelbase	y(mm)	1215	1327
重量 Weights	2.1	重量(包括蓄电池) W eight (including battery)	kg	1330	1570
	2.2	满载时桥负荷,驱动侧 /承重侧 Full -load axle load, drive/load -carrying end	kg	990/1940	1160/2410
	2.3	空载时桥负荷,驱动侧 /承重侧 No -load axle load, drive/load -carrying end	kg	890/4 40	1040/540
车轮	3.1	轮胎(橡胶胎,高性能弹性体,气胎胎,聚氨酯胎) Tires (Rubber tires, hyperelastic tires, air inflated tires, and polyurethane tires)		聚氨酯胎 Polyurethane wheels	
	3.2	轮子尺寸 驱动侧 Wheel size, drive end	Oxw(mm)	Ø230×70	
	3.3	轮子尺寸 承重侧 Wheel size, load -carrying end	Oxw(mm)	Ø84×70	
	3.4	转向轮尺寸 Steering wheel size	Oxw(mm)	Ø150×54	
	3.5	轮子数量(X=驱动轮) 驱动侧 /承重侧 Number of wheels (X = drive wheel), drive/load -carrying end		1×1/4	
	3.6	轮距(前部) 驱动侧 Wheel tread (Front), drive end	b10(mm)	510	
	3.7	轮距(后部) 承重侧 Wheel tread (Rear), load -carrying end	b11(mm)	390/502	
尺寸	4.1	降低时门架高度 Mast height during lowering	h1(mm)	2410	2228
	4.2	自由提升高度 Free lifting height	h2(mm)	1820	1520
	4.3	提升高度 Lifting height	h3(mm)	5430	4530
	4.4	门架可延伸高度 Mast extensible height	h4(mm)	6110	5208
	4.5	手柄在最小/最大驱动位置时的高度 Height of handle at minimum/maximum drive position	h14(mm)	950/1350	
	4.6	降低时高度 Height during lowering	h13(mm)	90	
	4.7	总体长度 Overall length	l1(mm)	1896 ¹⁾	2025 ¹⁾
	4.8	距货叉面长度 Length to fork face	l2(mm)	746 ¹⁾	875 ¹⁾
	4.9	总体宽度 Overall width	b1(mm)	790	
	4.10	货叉尺寸 Fork size	s/e1(mm)	60/180/1150	
	4.11	货叉外宽 Outer width of forks	b5(mm)	570/685	
	4.12	最小离地间隙 Minimum ground clearance	m2(mm)	28	23
	4.13	托盘 1000×1200 交叉时通道宽度 Aisle width for pallets 1,000×1,200 crosswise	As1(mm)	2325 ¹⁾	2455 ¹⁾
	4.14	托盘 800×1200 交叉时通道宽度 Aisle width for pallets 800×1,200 crosswise	As1(mm)	2290 ¹⁾	2420 ¹⁾
	4.15	转弯半径 Turning radius	Wa(mm)	1420 ¹⁾	1550 ¹⁾
性能 Performances	5.1	行驶速度 满载 /空载 Traveling speed, full -load/no -load	km/h	6.0/7.0	6.0/7.0
	5.2	提升速度 满载 /空载 Lifting speed, Full -load/no -load	mm/s	130/200	130/200
	5.3	下降速度 满载 /空载 Lowering speed, full -load/no -load	mm/s	280/230	280/230
	5.4	最大爬坡能力 满载 /空载 Maximum gradeability, full -load/no -load	%	6/12	6/10
	5.5	行车制动 Service brake		电磁制动 Electromagnetic brake	
电机 Motor	6.1	驱动电机功率 Drive motor power	kW	1.4	1.4
	6.2	提升电机功率 Lifting motor power	kW	3.2	3.2
	6.3	蓄电池,根据 DIN 43531/35/36 A, B, C 标准 Battery, as per DIN 43531/35/36 A, B, C standard		3VBS	3PZS
	6.4	蓄电池电压,额定容量 Battery voltage, rated capacity	V/Ah	24/210 -27 0	24/270 -350
	6.5	蓄电池重量 Battery weight	kg	185 -235	235 -285
	6.6	能量消耗 根据 VDI 循环标准 Energy consumption, as per VDI cycle standard	kWh/h	1.34	1.70
其它 Others	7.1	驱动控制方式 Drive control mode		交流速度控制 AC speed control	
	7.2	驾驶员耳边噪声水平 Driver's parotic noise level	dB(A)	<69	

1) 踏板放下: +440mm
1) Lowered footplate size: +440mm.

随技术进步,产品结构、参数等将不断改进,恕不另行通知。样本信息与实物略有不符的,以实物为准。
The continuous improvements of product structure and parameters along with the technologic progress will be made without further notice. In event of any discrepancy between brochure information and real product, the real product shall prevail.

前移叉车 ▼ Reach Forklift

站驾式前移叉车——XCF-PG15/20/25

Stand-on reach forklift - XCF-PG15/20/25

产品特点: Best-selling

在行驶过程中进行制动时,电机自动断电,最大限度地减少电能消耗,延长电池工作时间。
In event of braking during traveling, the motor is cut off automatically to minimize the consumption of electric energy and prolong the working time of battery.

采用电转向、全交流系统,进口驱动及转向电机, DIN标准大容量电池。国际先进的接头、软管和耐磨、耐高温、高柔性的进口密封件,结合合理的管路布局,保证了整机液压系统的冷却性、密封性、耐久性、安全性和高效性。

It's applied with electric steering, full-AC system, imported drive and steering motors, and DIN high-capacity battery. The world's leading connectors and hoses and the wear and heat resistant imported flexible seals are combined with reasonable pipeline layout to guarantee the cooling performance, sealing performance, durability, safety, and high efficiency of the machine hydraulic system.

电能、计时、故障显示功能便于操作了解车辆状况并及时进行维修保养。电器系统表面材料防水防尘,中央控制单元全封闭式的散热设计,使电路更简单可靠。

The power level, working time, and trouble code display functions enable the operator to understand the machine status and fulfill timely repairs and maintenances. The water-proof and dust-proof surface materials for the electric system and the full-enclosed head dissipation design for the central control unit guarantee simpler and more reliable electric circuits.

门架管路系统设置安全阀,有效控制货物的下降速度。高标准的工艺以及高质量的材料,使叉车在恶劣的工况下同样表现卓越。

The mast pipeline system is installed with safety speed-limiting valve to effectively control the lowering speed of the cargo. The high-standard processes and high-quality materials guarantee the outstanding performances of forklift even under severe working conditions.

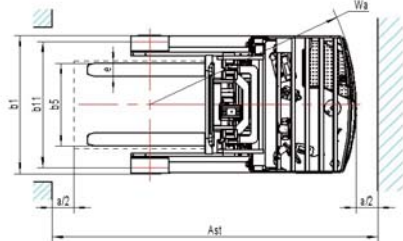
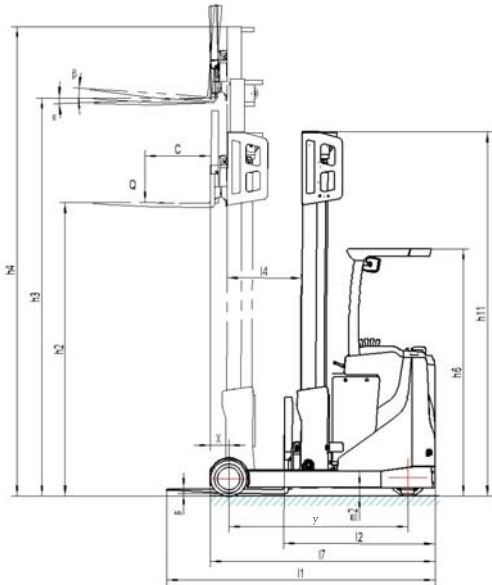

工业车辆参数表 Industrial vehicle specification							
特性 Characteristics	1.1	型号 Model	XCF -PG25	XCF -PG20	XCF -PG15		
	1.2	动力 (电动机、柴油、汽油、液 化石油气、电气) Power system (Motor, diesel, gasoline, LPG, or electric)	电动 Electric	电动 Electric	电动 Electric		
	1.3	驾驶 方式(手动式、步行式、 站驾式、驾驾式、推运式) Driving mode (Manual, walkie, stand - on, sit - on, and order picking)	站驾式 Stand - on type	站驾式 Stand - on type	站驾式 Stand - on type		
	1.4	额定 负载 Rated load capacity	Q(t)	2.5	2.0	1.5	
	1.5	载荷中心距 Center distance of load	c(mm)	500	500	500	
	1.6	前悬距 Front overhang	x(mm)	208	208	380	
	1.7	轴距 Wheelbase	y(mm)	1636	1500	1482	
重量 Weights	2.1	自重 (包括蓄电池) Dead weight (including ba ttery)	kg	3650	3550	3630	
车轮 Wheels	3.1	轮胎 (橡胶轮、高弹性弹性体、 聚氨酯、聚氨酯轮胎) Tires (Rubber tires, hyporelastic tires, air inflated tires, and polyurethane tires)		聚氨酯轮 Polyurethane wheels	聚氨酯轮 Polyurethane wheels	聚氨酯轮 Polyurethane wheels	
	3.2	轮子尺寸 驱动侧 Wheel size, d rive end	Øxw(mm)	343×140	343×140	343×140	
	3.3	轮子尺寸 承重侧 Wheel size, load - carrying end	Øxw(mm)	330×100	330×100	267×106	
	3.4	轮子数量 (X= 驱动轮) 驱动侧 / 承重侧 Number of wheels (X = drive wheel), drive/load - carrying end		2/1x	2/1x	2/1x+2	
	3.5	轮胎, 承重侧 Wheel tread, l oad - carrying/drive end	b1(mm)	1155	1155	1010/660	
尺寸 Dimensions	4.1	叉车倾角前后 Fork inclination, front/rear	α(°)	2/4	2/4	2/4	
	4.2	门架缩回高度 Height with masts retracted	h1(mm)	2335	2335	3340	
	4.3	自由提升高度 Free lifting height	h2(mm)	1420	1420	2665	
	4.4	提升高度 Lifting height	h3(mm)	5000	5000	8000	
	4.5	作业时门架最大高度 Maximum mast height during operations	h4(mm)	5915	5915	8865	
	4.6	护顶架高度 Overhead guard height	h6(mm)	2260	2260	2236	
	4.7	总体长度 Overall length	l1(mm)	2450	2380	2340	
	4.8	叉臂垂直面的长度 Length to fork vert ical face	l2(mm)	1380	1310	1326	
	4.9	车体宽度 Body width	b1(mm)	1260	1260	1130	
	4.10	叉叉尺寸 Fork size	s/e1(mm)	40/120/1070	40/120/1070	35/100/1070	
	4.11	叉叉外间距 (最小 /最大) Fork outer spacing (Minimum/maximum)	b5(mm)	240/760	240/760	200/760	
	4.12	前移距离 Reach dis tance	l4(mm)	710	645	560	
	4.13	最小离地间隙 Minimum ground clearance	m1(mm)	75	75	80	
	4.14	直角堆垛通叉宽度 (1,200° 沿叉叉位置) Right - angle stacking aisle width 800 × 1,200 (1,200 fork lengthwise)	Ast(mm)	2870	2800	2695	
4.15	转弯半径 Turning radius	Wa(mm)	1880	1750	17 50		
4.16	至轮臂最前端的长度 Length to wheel arm foremost end	l7(mm)	2050	1920	1855		
性能 Performances	5.1	行驶速度 满载 / 空载 Traveling speed, full - load/no - load	km/h	10.5/10.5	10.5/10.5	9.5/9.5	
	5.2	提升速度 满载 / 空载 Lifting speed, Full - load/no - load	mm/s	270/380	270/380	280/ 320	
	5.3	下降速度 满载 / 空载 Lowering speed, full - load/no - load	mm/s	450/400	450/400	350/310	
	5.4	前移速度 满载 / 空载 Forward speed, full - load/no - load	mm/	100/100	100/100	90/120	
	5.5	最大爬坡能力 Maximum gradeability full - load/no - load	%	10/15	10/15	10/15	
	5.6	行车制动 Service brake	电磁制动 Electromagnetic brake	电磁制动 Electromagnetic brake	电磁制动 Electromagnetic brake	电磁制动 Electromagnetic brake	
电机 Motor	6.1	驱动电机功率 S2 60min Drive motor power S2 60min	kW	6.4	6.4	5.5	
	6.2	提升电机功率 S3 15 % S3 15 % Lifting motor power	kW	12.5	12.5	8.6	
	6.3	蓄电池根据 A、B、C 无 Battery, as per DIN 43531/35/36 A、B、C no standard		A,4Pzs	A,4Pzs	A,4Pzs	
	6.4	蓄电池电压、额定容量 Battery voltage, rated capacity	K5	V/Ah	48/480	48/480	48/360
	6.5	蓄电池重量 Battery weight	kg	939	939	600	
其它 Others	7.1	驱动控制方式 Drive control mode		三相交流 Three - phase AC	三相交流 Three - phase AC	三相交流 Three - phase AC	
	7.2	系统压力 System pressure	(bar)	170	150	110	
	7.3	系统流量 System flow	(l/min)	35	35	40	
	7.4	驾驶员耳边噪声水平 EN12053 标准 Driver's parotic noise level, as per EN12053	根据	dB(A)	<70	<70	<70

随技术进步,产品结构、参数等将不断改进,恕不另行通知。样本信息与实物略有不符的,以实物为准。

The continuous improvements of product structure and parameters along with the technologic progress will be made without further notice.In event of any discrepancy between brochure information and real product, the real product shall prevail.

前移叉车 ▼ Reach Forklift

座驾式前移叉车——XCF-PSG16/20

Stand-on reach forklift - XCF-PSG16/20

产品特点: Best-selling

智能前取侧拉式电池结构, 电池更换简单快捷, 一气呵成。
The intelligent front-mounted side-pull battery structure guarantees the simple and easy replacement of battery.

配备可调节座椅, 操作舒适。
The adjustable seat is installed to ensure comfortable operations.

门架管路系统设置安全限速阀, 有效控制货物的下降速度。高标准的工艺以及高质量的材料, 使叉车在恶劣的工况下同样表现卓越。
The mast pipeline system is installed with safety speed-limiting valve to effectively control the lowering speed of the cargo. The high-standard processes and high-quality materials guarantee the outstanding performances of forklift even under severe working conditions.

国际先进的接头、软管和耐磨、耐高温、高柔性的进口密封件, 结合合理的管路布局, 保证了整机液压系统的冷却性、密封性、耐久性、安全性和高效性。
The world's leading connectors and hoses and the wear and heat resistant imported flexible seals are combined with reasonable pipeline layout to guarantee the cooling performance, sealing performance, durability, safety, and high efficiency of the machine hydraulic system.

电能、计时、故障显示功能便于操作人员了解车辆状况并及时进行维修保养。
The power level, working time, and trouble code display functions enable the operator to understand the machine status and fulfill timely repairs and maintenances.

电器系统表面材料防水防尘, 中央控制单元全封闭式的散热设计, 使电路更简单可靠。
The water-proof and dust-proof surface materials for the electric system and the full-enclosed head dissipation design for the central control unit guarantee simpler and more reliable electric circuits.

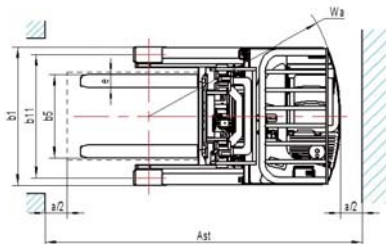
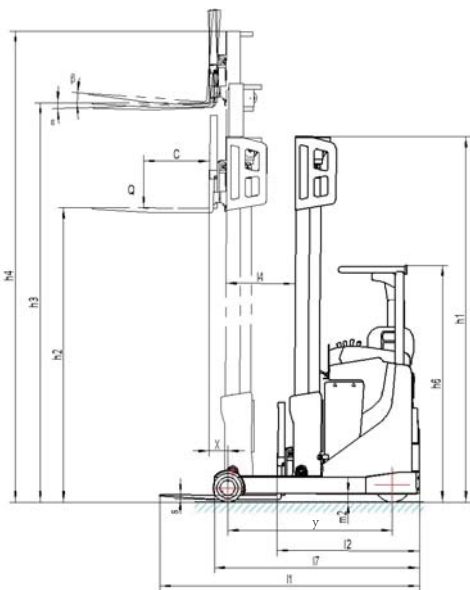

工业车辆参数表 Industrial vehicle specification					
特性 Characteristics	1.1	型号 Model		XCF -PSG20	XCF -PSG16
	1.2	动力 (电动, 柴油, 汽油, 液化石油气, 电) Power system (Motor, diesel, gasoline, LPG, or electric)		Electric	Electric
	1.3	驾驶方式 (手动式, 步行式, 站驾式, 座驾式, 拣选式) Driving mode (Manual, walkie, stand sit -on, and order picking)		座驾式 Sit -on type	座驾式 Sit -on type
	1.4	额定负载 Rated load capacity	Q(t)	2.0	1.6
	1.5	载荷中心距 Center distance of load	c(mm)	600	600
	1.6	前悬距 Front overhang	x(mm)	208	180
	1.7	轴距 Wheelbase	y(mm)	1500	1400
重量 Weights	2.1	自重 (包括蓄电池) Dead weight (including battery)	kg	3550	3000
	3.1	轮胎 (橡胶胎, 高性能弹性体, 气胎胎, 聚氨酯轮胎) Tires (Rubber tires, hyperelastic tires, air inflated tires, and polyurethane tires)		聚氨酯轮 Polyurethane wheels	聚氨酯轮 Polyurethane wheels
车轮 Wheels	3.2	轮子尺寸 驱动侧 Wheel size, drive end	Øxw(mm)	343×140	343×140
	3.3	轮子尺寸 承重侧 Wheel size, load -carrying end	Øxw(mm)	330×100	267×135
	3.4	轮子数量 (X= 驱动轮) 驱动侧 / 承重侧 Number of wheels (X = drive wheel), drive/load -carrying end		2/1x	2/1x
	3.5	轮胎, 承重侧 / 驱动侧 Wheel tread, load -carrying/drive end	b11(mm)	1155	1124
	尺寸 Dimensions	4.1	货叉倾角前后 Fork inclination, front/rear	α(β)(°)	2/4
4.2		门架缩回高度 Height with mast retracted	h1(mm)	2335	2335
4.3		自由提升高度 Free lifting height	h2(mm)	1420	1420
4.4		提升高度 Lifting height	h3(mm)	5000	5000
4.5		作业时门架最大高度 Maximum mast height during operations	h4(mm)	5915	5915
4.6		护顶架高度 Overhead guard height	h6(mm)	2160	2160
4.7		总体长度 Overall length	l1(mm)	2380	2300
4.8		至货叉垂直面的长度 Length to fork vertical face	l2(mm)	1310	1230
4.9		车体宽度 Body width	b1(mm)	1260	1260
4.10		货叉尺寸 Fork size	s/e/l(mm)	40/120/1070	40/120/1070
4.11		货叉外间距 (最小 / 最大) Fork outer spacing (Minimum/maximum)	b5(mm)	240/760	240/760
4.12		前移距离 Reach distance	l4(mm)	645	595
4.13		最小离地间隙 Minimum ground clearance	m1(mm)	75	75
4.14		直角堆垛通道宽度 800×1200 (沿货叉放置) Right -angle stacking aisle width (1,200 fork lengthwise)	Ast(mm)	2800	2730
4.15		转弯半径 Turning radius	Wa(mm)	1750	1650
4.16	至轮臂最前端的长度 Length to wheel arm foremost end	l7(mm)	1920	1760	
性能 Performances	5.1	行驶速度 满载 / 空载 Traveling speed, full -load/no -load	km/h	10.5/10.5	10.5 /10.5
	5.2	提升速度 满载 / 空载 Lifting speed, Full -load/no -load	mm/s	270/380	270/380
	5.3	下降速度 满载 / 空载 Lowering speed, full -load/no -load	mm/s	450/400	400/350
	5.4	前移速度 满载 / 空载 Forward speed, full -load/no -load	mm/	100/100	100/100
	5.5	最大爬坡能力 满载 / 空载 Maximum grad eability, full -load/no -load	%	10/15	10/15
	5.6	行车制动 Service brake		电磁制动 Electromagnetic brake	电磁制动 Electromagnetic brake
电机 Motor	6.1	驱动电机功率 S2 60min Drive motor power S2 60min	kW	6.4	6.4
	6.2	提升电机功率 S3 15 % Lifting motor power S3 15 %	kW	12.5	12.5
	6.3	蓄电池根据 DIN 43531/35/36 A Battery, as per DIN 43531/35/36 A, B, C, no ne		A,4Pzs	A,3Pzs
	6.4	蓄电池电压, 额定容量 K5 Battery voltage, rated capacity K5	V/Ah	48/480 -600	48/360 -450
	6.5	蓄电池重量 Battery weight	kg	939	750
其它 Others	7.1	驱动控制方式 Drive control mode		三相交流 Three -phase AC	三相交流 Three -phase AC
	7.2	系统压力 System pressure	(bar)	150	150
	7.3	系统流量 System flow	(l/min)	38	35
	7.4	驾驶员耳边噪声水平 根据 EN12053 标准 Driver's parotic noise level, as per EN12053	dB(A)	<70	<70

随技术进步, 产品结构、参数等将不断改进, 恕不另行通知。样本信息与实物略有不符的, 以实物为准。
The continuous improvements of product structure and parameters along with the technologic progress will be made without further notice. In event of any discrepancy between brochure information and real product, the real product shall prevail.

牵引叉车 ▼ Tow Tractor

站驾式牵引车——XCT-P30

Stand-on tow tractor - XCT-P30



产品特点: Best-selling

整车设计结构紧凑,外形小巧美观,转弯半径小,机动性能好,无污染。This machine features compact structure design, exquisite and beautiful exterior, small turning radius, good mobility, and zero pollution.

整机重心低,车辆在转弯和行驶时稳定性好。Low gravity center of the machine guarantees good stability during steering and traveling.

多功能液晶仪表,外形美观,显示信息全面。The multifunctional LCD instruments feature beautiful exterior and all-round display information.

宽敞的操作空间和低位的上下车踏板使操作者上下车十分方便。The capacious operating space and the low-level boarding footplates really ease the operator's get-on and get-off.

配置安全方便的紧急按钮,紧急状态下可瞬间切断整车动力源,极大地增加了安全性。A safe and convenient emergency button is installed to transiently cut off the power source of the machine in event of any emergency, in order to remarkably improve the safety.

牵引车专用减速箱、驱动桥总成,结构紧凑,传动平稳。采用品牌电机,高效、性能可靠。The special reduction box and drive axle assembly for the tow tractor guarantee compact structure and stable drive. The installed brand motor features high efficiency and reliable performances.

车体尾部的点动开关具有点动功能,作业效率高。The inching switch on the tail of the machine body incorporates the inching function, featuring high working efficiency.

全新的交流动力系统提供了强大的动力,精确的调速性能及各种再生功能,操作更加安全可靠。All-new AC power system provides strong power, accurate speed regulation performance, and various regeneration functions to achieve higher operating safety and reliability.

交流电机免维护,减少维护保养费用的同时,提高了可靠性,效率更高,更可靠,使用寿命大大提高。The maintenance-free AC fan improves the reliability, realizes higher efficiency, and remarkably prolongs the life while reducing



不同挂钩高度
加强的牵引架拥有三个不同的挂钩高度,确保满足不同拖车多种需求和可靠连接。

Different hook heights
The reinforced traction frame is provided with three different hook heights to meet the diversified needs of towed vehicles and ensure reliable hitching.



显示器
数据均可由多功能显示器读出,它支持几种形式模式,并提供信息诊断。

Display
With display function of all data, the display supports different modes and provides the information diagnosis.



存放区域
包装保鲜膜存放区域

Storage area
Storage area for packaging preservative film.



操作舒适方便
后部握持的手柄符合人体工程学,使操作简单安全。后部座位可通过安装孔移位轻松调节。

Comfortable and convenient operations
The rear grip handle conforms to the ergonomic principles and ensures simple and safe operations. The rear seat can be easily adjusted by shifting the mounting holes.

工业车辆参数表 Industrial vehicle specification				
特性 Characteristics	1.1	型号 Model		XCT -P30
	1.2	动力 (电动, 柴油, 汽油, 液化石油气, 电) Power system (Motor, diesel, gasoline, LPG, or electric)		电动 Electric
	1.3	驾驶方式 (手动式, 步行式, 站驾式, 座驾式, 拣选式) Driving mode (Manual, walkie, stand-on, and order picking)		站驾式 Stand-on type
	1.4	额定承载能力 Rated load capacity	Q(t)	3.0
	1.5	额定拉架能力 Rated hitch capacity	F(N)	800
	1.6	轴距 Wheelbase	y(mm)	1051.5
重量 Weights	2.1	重量 (包括蓄电池) Weight (including battery)	kg	920
	2.2	空载时桥负荷 驱动侧 / 承重侧 No-load axle load, drive/load -carrying end	kg	560/360
车轮 Wheels	3.1	轮胎 (橡胶轮, 高性能弹性体, 气胎轮, 聚氨酯胎) Tires (Rubber tires, hyperelastic tires, air inflated tires, and polyurethane tires)		PU
	3.2	轮子尺寸 驱动侧 Wheel size, drive end	Oxw(mm)	Ø250×82
	3.3	轮子尺寸 承重侧 Wheel size, load -carrying end	Oxw(mm)	Ø180×76
	3.4	轮子数量 (X= 驱动轮) 驱动侧 / 承重侧 Number of wheels (X = drive wheel), drive/load -carrying end		1X/2
	3.5	轮距 (前侧) 驱动侧 Wheel tread (Front), drive end	b10 (mm)	-
	3.6	轮距 (后侧) 承重侧 Wheel tread (Rear), load -carrying end	b11(mm)	635
尺寸 Dimensions	4.1	操作手柄在中立位置时的高度 Height with handle in neutral position	h14(mm)	1450/1420/1340/1226
	4.2	牵引销 (挂钩中心离地) 高度 Traction pin height (Ground clearance of hook center)	h10 (mm)	230/324/420
	4.3	总体长度 Overall length	l1(mm)	1453
	4.4	车体宽度 Body width	b1(mm)	810
	4.5	轴距中心距地间隙 Ground clearance of wheelbase center	m2(mm)	50
	4.6	转弯半径 Turning radius	Wa(mm)	1348
性能 Performances	5.1	行驶速度 满载 / 空载 Traveling speed, full-load/no-load	Km/h	7.0/7.5
	5.2	拉架能力 满载 / 空载 Hitch capacity, full-load/no-load	N	800/-
	5.3	最大拉架能力 满载 / 空载 Maximum hitch capacity, full-load/no-load	N	2800/-
	5.4	行车制动 Service brake		电磁制动 Electromagnetic brake
电机 Motor	6.1	驱动电机功率 Drive motor power	kw	2.6
	6.2	电池, 英国 BS 标准, 无 Battery, BS standard, none		无, 3PZS None, 3PZS
	6.3	蓄电池电压, 容量 (5 小时放电率) Battery voltage/capacity (5h discharge capacity)	V/Ah	24/465
	6.4	电池重量 (+/-5%) Battery weight (+/-5%)	kg	363
其它 Others	7.1	驱动控制方式 Drive control mode		交流速度控制 AC speed control
	7.2	驾驶员耳边噪音水平 Driver's parotic noise level	dB(A)	70

随技术进步, 产品结构、参数等将不断改进, 恕不另行通知。样本信息与实物有不符的, 以实物为准。

The continuous improvements of product structure and parameters along with the technological progress will be made without further notice. In event of any discrepancy between brochure information and real product, the real product shall prevail.

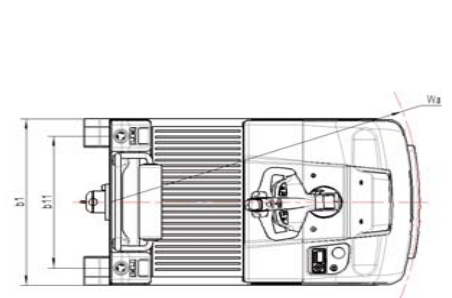
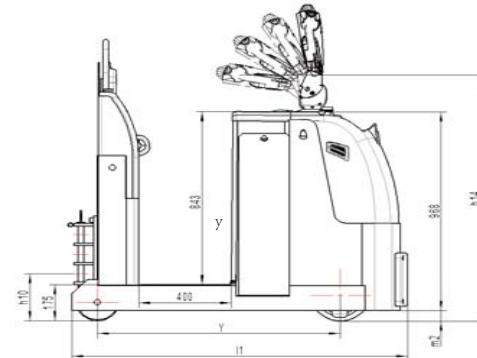

牵引车 ▼ Tow Tractor

站驾式牵引车——XCT-P50

Stand-on tow tractor - XCT-P50



产品特点：Best-selling

XCT-P50站驾式牵引车甄选德国三相交流驱动电机和意大利控制器，保证车辆动力更强劲，加减速度更平稳，同时搭配电子助力转向和德国REMA多功能手柄，保证高效的工作效率和驾驶舒适性。XCT-P50 stand-on tow tractor is equipped with German three-phase AC drive motor and Italian controller to ensure stronger machine power and more stable acceleration and deceleration and meanwhile is equipped with electronic power steering and German REMA multifunctional handle to ensure high working efficiency and driving comfort.

四点浮动式减震踏板和减震橡胶脚垫可大大减少震动传递给驾驶员者，同时搭配汽车级仿生曲面靠背，可有效降低驾驶员的驾驶疲劳度；另外本车采用侧拉式电池设计，可快速更换电池，满足多班工作使用要求。

The four-point floating damping footplate and the damping rubber mat can remarkably mitigate the vibration transmitted to the driver. Meanwhile, the car-level bionic curved backrest is installed to effectively mitigate the driver's driving fatigue. In addition, this machine adopts side-pull battery design to realize the quick swapping of battery and meet the multi-shift operation needs.

本车还提供扩展支架、警示灯、蓝光灯、电动牵引栓、大容量储物盒、双USB等配置或功能，让工作更轻松高效。

This machine is also provided with the equipment and functions, such as expansion bracket, warning lamp, blue lamp, electric traction pin, high-capacity storage box, and double USB port, to realize easier and more efficient operations.



侧面更换蓄电池，快捷方便。搭配高度可调节的电池搬运托架，可让电池更换更轻松快捷。

The side-swapping battery features high quickness and convenience. With the use of height adjustable battery switch on two sides can quickly realize the handling, it can realize quicker and more forward/backward movement of the machine near the machine. Meanwhile, the forward/backward speed of the machine controlled by the walkie switches is reduced to realize higher traction safety



双侧步行开关及急停开关，在车边即能快速实现车辆进退，同时降低了步行开关控制车辆进退的速度，让牵引更安全高效。

The walkie switch and emergency stop button on two sides can quickly realize the handling, it can realize quicker and more forward/backward movement of the machine near the machine. Meanwhile, the forward/backward speed of the machine controlled by the walkie switches is reduced to realize higher traction safety



警示灯让车辆行驶更安全。

The warning lamp guarantees driving safety of the machine.



双侧浮动式平衡轮，让车辆行驶更平稳安全。

higher the floating balance wheels on two sides achieve higher driving stability and safety of the machine.

工业车辆参数表 Industrial vehicle specification				
特性 Characteristics	1.1	型号 Model		XCT -P50
	1.2	动力 (电动, 柴油, 汽油, 液化石油气, 电气) Power system (Motor, diesel, gasoline, LPG, or electric)		电动 Electric
	1.3	驾驶方式 (手动式, 步行式, 站驾式, 座驾式, 搬运式) Driving mode (Manual, walkie, stand-on, sit-on, and order picking)		站驾式 Stand-on type
	1.4	额定承载能力 Rated load capacity	Q(t)	5.0
	1.5	额定拉架能力 Rated hitch capacity	F(N)	1000
	1.6	轴距 Wheelbase	y(mm)	1155
重量 Weights	2.1	重量 (包括蓄电池) Weight (including battery)	kg	1020
	2.2	空载时桥负荷 / 承重侧 No-load axle load, drive/load -carrying end	kg	610/410
车轮 Wheels	3.1	轮胎 (橡胶轮, 高性能弹性体, 聚氨酯) Tires (Rubber tires, hyperelastic tires, and polyurethane tires)		实心橡胶轮 Solid rubber tires
	3.2	轮子尺寸 驱动侧 Wheel size, drive end	Øxw(mm)	250*80
	3.3	轮子尺寸 承重侧 Wheel size, load -carrying end	Øxw(mm)	180*76
	3.4	稳定轮 (尺寸) Stabilizing wheel (Size)	Øxw(mm)	124*60
	3.5	轮子数量 (X=驱动轮) 驱动侧 / 承重侧 Number of wheels (X=drive wheel), drive/load -carrying end		1x+2/2
	3.6	轮距 驱动侧 Wheel tread, drive end	b10(mm)	580
	3.7	轮距 承重侧 Wheel tread, load -carrying end	b11(mm)	614
尺寸 Dimensions	4.1	操作手柄在中立位置时的高度 Height with handle in neutral position	h14(mm)	1280
	4.2	牵引销 (挂钩中心离地) 高度 Traction pin height (Ground clearance of hook center)	h10(mm)	230/330/430
	4.3	总体长度 Overall length	l1(mm)	1429 ¹⁾
	4.4	车体宽度 Body width	b1(mm)	810
	4.5	最小离地间隙 (轴距中心) Minimum ground clearance (Wheelbase center)	m2(m m)	50
4.6	最小转弯半径 Minimum turning radius	Wa(mm)	1333 ²⁾	
性能 Performances	5.1	行驶速度 满载 / 空载 Traveling speed, full -load/no -load	Km/h	7/12
	5.2	拉架能力 满载 / 空载 Hitch capacity, full -load/no -load	N	1000
	5.3	最大拉架能力 满载 / 空载 Maximum hitch capacity, full -load/no -load	N	3000
	5.4	行车制动 Service brake		电磁制动 Electromagnetic brake
电机 Motor	6.1	驱动电机功率 Drive motor power	kw	2.6
	6.2	蓄电池根据 DIN 43531/35/36 A, B, C 标准 Battery, as per DIN 43531/35/36 A, B, C		no
	6.3	蓄电池电压; 额定容量 Battery voltage, rated capacity	V/Ah	24/465
	6.4	蓄电池重量 Battery weight	kg	352
其它 Others	7.1	驱动控制方式 Drive control mode		交流速度控制 AC speed control
	7.2	驾驶员耳边噪音水平, 根据 EN12053 标准 Driver's parotic noise level, as per EN12053	dB(A)	<70

1) 安装防撞垫 H=1469mm; 2) 安装防撞垫 Wa=1359mm
1) With installed impact pad H=1,469mm; 2) With installed impact pad Wa=1,359mm.

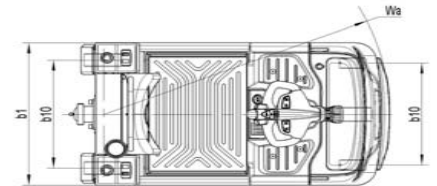
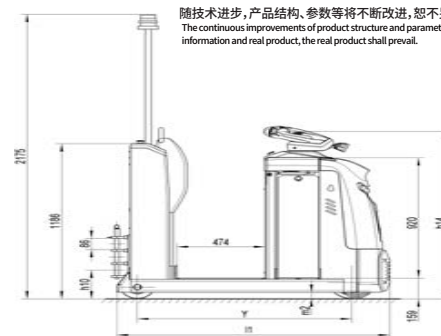

随技术进步, 产品结构、参数等将不断改进, 恕不另行通知。样本信息与实物略有不符的, 以实物为准。
The continuous improvements of product structure and parameters along with the technologic progress will be made without further notice. In event of any discrepancy between brochure information and real product, the real product shall prevail.

牵引车 ▼ Tow Tractor

座驾式牵引车——XCT-PS60

Stand-on tow tractor - XCT-PS60



产品特点: Best-selling

XCT-PS60蓄电池牵引车,额定载荷6000kg,整车造型新颖,符合人机工程原理。该车三轮支承,后轮驱动。具有低噪音、牵引力大、操作简便、设计结构紧凑、机动性好等特点,适合比较狭窄的作业条件。能源清洁,无污染,侧出式蓄电池拆装,并配有电池更换架,方便可靠。多功能液晶仪表,显示信息量大。宽敞的操作空间和低位的上下车踏板使操作者上下车十分方便。采用品牌牵引电机,高效性能可靠。全新的交流动力系统提供了强大的动力。交流电机免维护,减少维护保养费用,提高了可靠性,效率更高,更可靠,使用寿命更高。整车重心低,车辆在转弯和行驶时稳定性好。

XCT-PS60 battery tow tractor features novel modeling and conforms to ergonomic principles, with rated load capacity at 6,000kg. This machine is supported by three wheels and is driven by rear wheels. Featuring low noise, high traction force, simple operations, compact structure design, and good mobility, it's suitable for the relatively narrow working conditions. The clean energy features zero pollution and the side-pull battery structure is attached with battery swapping bracket to ensure high convenience and reliability. The multifunctional LCD instruments provide extensive display information. The capacious operating space and the low-level boarding footplates really ease the operator's get-on and get-off. The installed brand traction motor features high efficiency and reliable performances. All-new AC power system provides strong power. The maintenance-free AC fan reduces the maintenance cost, improves the reliability, realizes higher efficiency, and prolongs the life. Low gravity center of the machine guarantees good stability during steering and traveling.

此牵引车在操纵者的左侧装有紧急断电开关,在紧急情况下直接按下此按钮可以切断整车电源,保证了行驶的安全性。采用减速箱、驱动桥、结构紧凑,传动平缓。车子尾部两侧装有慢速(点动)的前进后退开关,方便与后面拖车的连接和断开,提高作业效率。驻车制动采用悬挂脚踏式,加速器踏板也采用悬挂式,操作时方便、舒适。车子尾部配有方形货框,加大储物空间。牵引高度有多种可选。车子尾部配有航空插头,可以给后面的拖车提供大灯、警示灯的电源。

This tow tractor is installed with an emergency cutoff switch on the left side of the operator. In event of any emergency, directly push down this button to power off the machine and guarantee the driving safety. The installed reduction box and drive axle feature compact structure and smooth drive. The low-speed (inching) forward/reverse switches are installed on two sides of the machine tail to ease the hitching and unhitching of towed vehicle behind and improve the working efficiency. The suspended foot-operated parking brake and the suspended accelerator pedal are applied to achieve convenient and comfortable operations. The tail of the machine is installed with a square cargo container to expand the storage space. The multiple hitching heights are provided at your choice. The machine tail is installed with an aviation connector to power on the headlamp and warning lamp of the towed vehicle.

工业车辆参数表
Industrial vehicle specification

工业车辆参数表 Industrial vehicle specification				
特性 Characteristics	1.1	型号 Model		XCT-PS60
	1.2	动力 (电动, 柴油, 汽油, 液化石油气, 电 气) Power system (Motor, diesel, gasoline, LPG, or electric)		电动 Electric
	1.3	驾驶方式 (手动式, 步行式, 站驾式, 座驾 式, 拣选式) Driving mode (Manual, walkie, stand -on, sit-on, and order picking)		座驾式 Sit-on type
	1.4	额定承载能力 Rated load capacity	Q(t)	6.0
	1.5	额定牵引力 Rated traction force	F(N)	1500
	1.6	最大牵引力 Maximum traction force	F(N)	4500
	1.7	轴距 Wheelbase	y(mm)	1230
重量 Weights	2.1	重量 (包括蓄电池) Weight (including battery)	kg	1640
车轮 Wheels	3.1	轮胎 (橡胶轮, 高性能弹性体, 气胎轮, 聚 胺脂轮胎) Tires (Rubber tires, hyperelastic tires, air inflated tires, and polyurethane tires)		橡胶 Rubber
	3.2	轮子尺寸 - 驱动侧 Wheel size, drive end	Øxw(mm)	6.50 - 10
	3.3	轮子尺寸 - 承重侧 Wheel size, load -carrying end	Øxw(mm)	4.00 - 8
	3.4	轮子数量 (X=驱动轮) Number of wheels (X = drive wheel)		2x/1
	3.5	轮距 (前面) Wheel tread (Front)	b10(mm)	/
	3.6	轮距 (后面) - 驱动轮 Wheel tread (Rear), drive end	b11(mm)	893
尺寸 Dimensions	4.1	总体高度 Overall height	h14(mm)	1390
	4.2	总体长度 Overall length	l1(mm)	2020
	4.3	车体宽度 Body width	b1(mm)	1140
	4.4	最小离地间隙 Minimum ground clearance	m2(mm)	135
	4.5	转弯半径 Turning radius	Wa(mm)	1745
性能 Performances	5.1	行驶速度 满载 / 空载 Traveling speed, full -load/no -load	Km/h	9.0/13
	5.2	行车制动 Service brake		液压 Hydraulic
电机 Motor	6.1	驱动电机功率 Drive motor power	kw	6.8
	6.2	电池, 标准, 无 Battery, standard, none		DIN
	6.3	蓄电池电压、容量 Battery voltage/capacity	V/Ah	48/300
	6.4	电池重量 (+/-5%) Battery weight (+/-5%)	kg	490
其它 Others	7.1	驱动控制方式 Drive control mode		场效应管控制 AC Field effect tube control AC
	7.2	驾驶员耳边噪音水平 Driver's ear noise level	dB(A)	70

随技术进步, 产品结构、参数等将不断改进, 恕不另行通知。样本信息与实物略有不符的, 以实物为准。

The continuous improvements of product structure and parameters along with the technologic progress will be made without further notice. In event of any discrepancy between brochure information and real product, the real product shall prevail.

